

This is a reproduction of a library book that was digitized by Google as part of an ongoing effort to preserve the information in books and make it universally accessible.

Google™ books

<https://books.google.com>

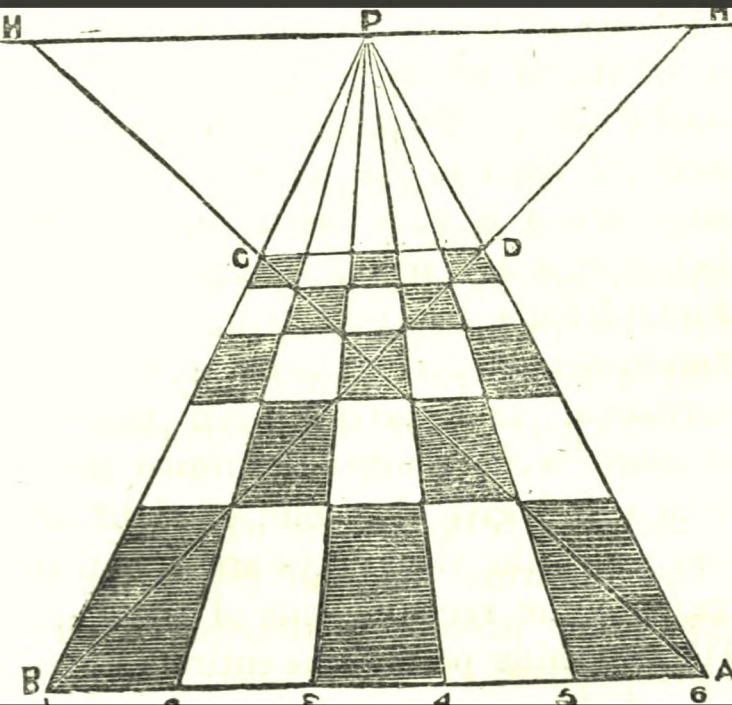



*The complete
guide to the fine arts*

Complete guide



600047489

41.

35.

THE
COMPLETE GUIDE
TO THE
FINE ARTS:

CONTAINING INSTRUCTIONS IN
THE ART OF DRAWING, OIL COLOUR PAINTING,
WATER COLOUR PAINTING,
PERSPECTIVE, FLOWER PAINTING,
MINIATURE PAINTING, ORIENTAL TINTING,
CRAYON PAINTING, LITHOGRAPHIC DRAWING,
ENGRAVING ON WOOD AND COPPER,
SKETCHING FROM NATURE, ETC., ETC.
VALUABLE RECIPES, ETC.

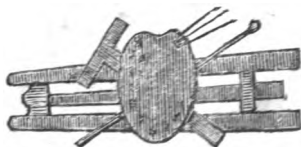

LONDON :
W. BRITAIN, PATERNOSTER ROW,
T. SLOPER, HIGH STREET, MARYLEBONE,
AND ALL BOOKSELLERS.

1841.



P R E F A C E .

IN the following work the author has endeavoured as much as possible to point out to the student the easiest and most approved methods of practice in the various arts contained in this volume.

Although it may be beneficial to become acquainted with any successful means by which others have attained excellence, yet every one, by diligence, ought to form a correct style of his own; and the student may rest assured, that in most cases in which great proficiency has been attained, no small degree of trouble has been endured, and many failures have taken place before the artist has been finally successful. Let nature be his principal study; for the nearer he approaches nature in his representations the higher will be his excellence as an artist, for

Who can paint
Like nature? Can imagination boast
Amid its gay creations hues like hers?

THOMSON.

CONTENTS.

	PAGE
OIL PAINTING	1
Necessary Materials	2
PORTRAIT PAINTING	5
Principal Colours	6
Progress of the Painting	9
Draperies, painting of	13
Back-grounds, painting of	22
Rules for the Painter, by Sir Joshua Reynolds	26
Painting a Head	28
LANDSCAPE PAINTING	29
Colours, principal	30
Second Painting	33
Third Painting	37
RECIPES, &c.—To Prepare Cloth, or Canvas .	41
Megilph, to make	42
Pictures, to clean	42
Transferring Old Paintings to New Canvas .	44
DRAWING and SKETCHING FROM NATURE .	49
Implements and Materials	49
Instructions, general	53
Drawing the Figure	56
Human Figure, proportions of	60
LANDSCAPE DRAWING	62
SKETCHING FROM NATURE	65
RECIPES, &c. — To Fix Black-lead Pencil	
Drawings	77
Tracing Paper, to make	78
Easy method of taking a perfect Copy from	
Print or Drawing	78
Black-lead Paper	80
PERSPECTIVE, THE ART OF DRAWING IN .	81

	PAGE
Terms, &c.	83
Horizontal Line and Point of Sight	89
Perspective, practical examples in	92
Aerial Perspective	110
RECIPES, &c.—To Colour unsized Prints	111
Papier Machee	111
MINIATURE PAINTING, THE ART OF	113
Colours, &c,	113
Ivory, method of choosing and preparing	115
Tints, compound	117
Draperies, painting of	118
Painting the Face in Miniature	120
CRAYON PAINTING	125
GRECIAN or PERSIAN PAINTING	135
RECIPES, &c.—Bleaching Ivory	139
To make Black Chalk and Coloured Crayons	139
Ivory Paper	140
WOOD, THE ART OF ENGRAVING ON	145
Tools used in ditto	149
LITHOGRAPHIC DRAWING	156
Materials, &c.	157
ENGRAVING ON COPPER	163
Colours for Painting on Velvet, Satin, &c.	168
RECIPES, &c.—To make Red Chalk Crayons	171
To Clean Copper-plates	173
Painting on Vellum	174
Painting Transparencies	174
WATER COLOUR PAINTING	177
FLOWER PAINTING	191
ORIENTAL TINTING, or POONAH PAINTING	194
Directions, &c.	195
THE ART OF STAINING GLASS	201

Water Colour Painting.—First Stage, or Dead Colouring.



Plate I.

See page 181.

Water Colour Painting.



Plate II.

See page 183.

Water Colour Painting.



Plate III.

See page 186.

THE PALETTE

WITH THE

COLOURS FOR THE FIRST AND SECOND PAINTING OR
SITTINGS FOR A PORTRAIT.

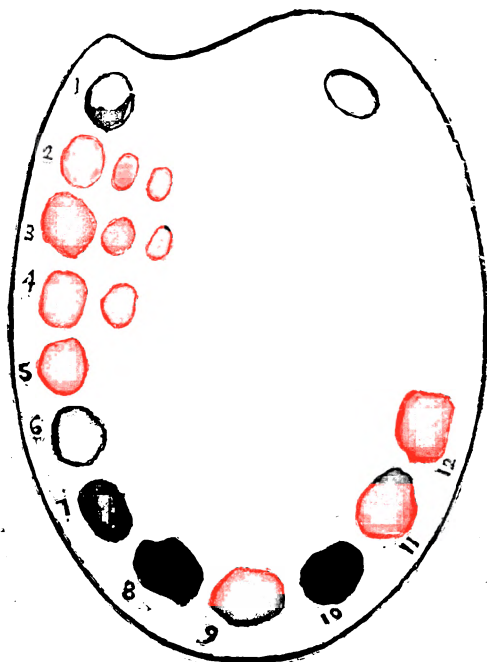

1. White.
2. Yellow Ochre and tints.
3. Light Red and tints.
4. Vermilion and tints.
5. Lake, Vermilion, and White.
6. Rose tint.

7. Blue tint.
8. Lead tint.
9. Half Shade tint.
10. Shade tint.
11. Red tint.
12. Warm tint.

THE COMPLETE GUIDE

TO THE

FINE ARTS.

Painting in Oil Colours, &c.

OIL painting, which exceeds all other methods in its accuracy of colours, and in its wonderful force and expression, although it might have been previously known, was greatly improved and first practised generally by Jan. Van Eyek, commonly called John of Bruges, about 1415.

It is preferable to all other methods, as it admits of a perfect gradation of tints in the most durable of all materials for painting, and allows the painter to finish smooth and retouch his works with the greatest care and precision. The colours also being more blended together,

produce the most agreeable gradations and delicacy of effect.

We hope the following pages contain something that may be of consequence in the acquisition of this noble art, and that the practical method of colouring here laid down, (which has been the result of much study and long experience,) will be found both useful and agreeable. We shall present the student with the best rules, drawn from a careful study of the works of Vandyck and Rembrandt, two of the most remarkable colourists in different styles. These rules are arranged in so easy a method that the student may be led step by step through all the difficulties of this nice and pleasing progress.

NECESSARY MATERIALS.

The principal materials required are a palette, palette knife, an easel, picture cloths, a maul stick, pencils, tools or brushes, charcoal, black chalk, tin cups to hold oil, &c., varnishes, oils, oil colours, &c.

The palette is used to contain the

colours. To set the palette is to place the colours thereon in their proper order. The light colours are placed next the hand, the darker ones next, increasing in depth according to their distances from the front. A second row of tints is then formed of the original colours, by mixing these together in such proportions as to produce tints to suit the subject of the piece. A third row of tints must also be made, which should, if possible, approach nearer the complexion of the piece than the second row.

The oil colours are generally kept in bladders, and when required for use, the bladder is pricked with a pin or small tin tack. A patent has lately been taken out for keeping the oil colours in bottles, it has not come into general use.

The palette knife is a thin well tempered blade; its use is to mix up the colours on the palette.

Pencils are generally of two sorts, viz. camels' hair and fitch. Fitch pencils are used by some artists to give a smoothness to their pictures, by working the

colours into each other after they have been laid on with the camels' hair pencil. This is called scumbling the colours. Others who wish to give a bold appearance to their works, paint entirely with fitches. Tools are only a larger kind of pencils, not inserted into quills like the foregoing, but the hairs are bound round a stick, in the manner of the brushes used by house painters—some good artists have used no others. There is also another kind of pencils, having very long hairs, chiefly used by marine painters to describe the ropes, &c., in shipping.

The easel is formed in different ways, according to the fancy of the artist; the most common form for it, is three straight legs, the longest being behind. Picture cloths are those substances upon which the picture is painted: directions for preparing them will be given at the end of the work.

The maul stick is a slender rod of wood, with a ball of cotton or some other soft substance tied to one end, to rest against the picture without damaging it. Its use

is to support the right hand while at work. This implement is not in universal use; many artists wholly reject it as being pernicious to that freedom of hand necessary to a good painter.

Portrait Painting.

Of the principal colours used in the painting of flesh, and from which all the tints are made.

THE various bodies employed by painters may be termed either pigments or fluids, as they are solid or aqueous; but their variety are two numerous to be in general use; most painters therefore select a set out of them, and become very unjustly prejudiced against those they reject.

Those colours which become transparent in oil, such as lake, Prussian blue, and brown pink, are frequently used without the admixture of white, or any opaque pigment, by which means the tint of the ground on which they are laid retains, in some degree, its force, and the

real colour produced in painting is the combined effect of both. This is called *glazing*, and the pigments endued with the property of becoming transparent in oil, are called glazing colours.

PRINCIPAL COLOURS.

Flake white, or fine white.—This colour must be ground with the finest poppy oil that can be procured, or it will turn yellow if the oil is not pure. White comes forward to the eye with yellows and reds, and retires with blues and greens.

Ivory black is the best : it is a colour which mixes kindly with all others : it is generally ground with linseed oil and used with drying oil : it is a cold retiring colour.

Ultramarine is the finest blue known : it is used with poppy oil. It is a beautiful glazing colour.

Prussian blue is a fine colour : it is best used with nut oil.

Yellow ochre is a good mixing colour,

and of great use in the flesh: it is best used with nut oil.

Light red, mixed with white, produces a fine flesh colour: it should be ground and used with nut oil.

Vermilion. — This colour should never be used unless genuine. It is a fine colour when glazed; used with drying oil.

Carmine should be ground with nut oil and used with drying oil.

Lake is ground with linseed oil, and used with drying oil: it is the best glazing colour that can be used.

Indian Red is ground and used as the lake.

Brown Pink is a fine glazing colour, ground with linseed oil, and used with drying oil: it is one of the finishing colours, and should not be used in the first painting: it is strengthened with burnt umber, and weakened with terra-verte.

Burnt umber is a good working strong colour, is of great use in painting the hair, and mixes finely with the warm shade.

*Principal tints formed from the above,
necessary for painting flesh.*

Light red tint is made of light red and white; it is the best of all for the general ground of the flesh; with this colour and the shade tint you should make out the flesh like mezzotinto.

Vermillion tint is made of vermilion and white, mixed to a middle tint, and is the most brilliant light red that can be made.

Carmine tint is carmine and white; it is the best red for the cheeks and lips: it is one of the finishing colours and should not be used in the first painting.

Rose tint is made of the red shade and white mixed to a middle degree or lighter.

Yellow tint is made of Naples yellow, chrome, yellow ochre and white, which is a good working colour.

Blue tint—ultramarine and white, Prussian blue and white. No colour is so proper for blending down or softening the light into *keeping*.

Lead tint is made of ivory black and white ; shade tint is composed of lake, Indian red, black and white mixed to a middle tint : this is the best mixture for the general ground of shadows.

Red shade is lake and a little Indian red : it is a good glazer, and an excellent ground for all dark shadows.

Warm shade is lake and brown pink.

Dark shade is made of ivory black and a little Indian red : it is good for glazing the eye-brows and darkest shadows.

PROGRESS OF THE PAINTING.

With regard to the progress of a picture no rule can be given that will universally serve to direct the student—the judgment is the principal guide. The only general method that can be given is the following :—

The outline of the figure must be faintly sketched with white chalk, and afterwards more correctly formed with the pencil, and any thin transparent colour, and is then divided into three stages or paintings.

The colours and tints necessary for the first and second stages of painting flesh are—1. Flake white. 2. Yellow ochre and its tints. 3. Light red and its two tints. 4. Vermilion and its tint. 5. A tint composed of lake, vermilion, and white. 6. Rose tint. 7. Blue tint. 8. Lead tint. 9. Half shade tint, made of Indian red and white. 10. Shade tint. 11. Red shade. 12. Warm shade.

The finishing palette for a complexion requires five more, viz., 1. Carmine and its tint. 2. Lake. 3. Brown pink. 4. Ivory Black. 5. Prussian blue.

First stage, or dead colouring.

The first lay consists of two parts; the work of the shadows and the lights. The work of the shadows is to make out the drawing very correctly with the shade tint laid on sparingly. The lights should be all laid in with the light red tints, as we see them in nature.

For uniting the lights and shade you should use a long softener, which will help to bring the work into character;

then go over the darkest shadows with the red or warm shades which will finish the first lay. In order to finish the first painting improve the reds and yellows to the complexion, and after them the blues; the grounds of shadows should be such as will support the character of the finishing colours, which ground should be a little lighter than the finishing colours, because the finishing of the shadows is glazing. Every colour in drying will sink and partake in proportion to its body of the colour it is laid on, therefore all the lights of the flesh should be laid on a light ground.

Second painting, or second stage.

Begin with laying on the smallest quantity of poppy oil, then wipe it nearly all off with a silk handkerchief. The second painting is also divided into two parts. 1st. Scumbling the lights and glazing the shadows. 2nd. Finishing the complexion with the virgin tints, and improving, as far as you can, without

daubing. Scumbling is going over the lights where they are to be changed with the light red tints, or some other of their own colours, with short stiff pencils, but such parts only as require it.

The light red tint improved is the best colour for scumbling. When the shadows and drawing are to be corrected you should do it with the shade tint, by driving the colour very stiff and bare. Be very careful in uniting the lights and shades that they do not mix dead and mealy.

Secondly, go over the complexion with the virgin tints, which improve the colouring to the greatest perfection, both in the lights and shadows.

This should be done in the same manner as in the second part of the first painting, that is, with the reds, yellows, and blues, blending them with delicate light touches of the middle tints without softening. Leave the tints and their grounds clean and distinct and be content to leave off while the work is safe and unsullied, leaving what is further

required for the next sitting, for in attempting the finishing touches before the other is dry, you will lose the spirit and drawing, and your colours will become of a dirty hue.

Third painting or finishing.

Begin with correcting all the glazing, first, where the glazing serves as a ground or under part; then determine what should be done next, so that you may be able to make the alteration on the part with one stroke of the pencil. By this method you preserve both the glazing and the tints, but if it happens that you cannot lay such a variety of tints and finishing colours as you intended, it is better to leave off while the work is safe and in good order, because those few touches may be easily done if you have patience to stay till the colours are dry, and then, without oiling, add those finishings with free light strokes of the pencil.

Painting Draperies.

THE method of painting draperies in

general is to make out the whole or first lay with three colours only: viz., the lights, middle tint, and shade tint. The beauty and character of the folds, the shape, attitude, and principal lights and shades, are made with these three colours only.

It will be necessary to notice the general method of managing the colours of the first lay, and those of the reflections and finishing tints.

In the first lay the lights should be laid with plenty of stiff colour, and then shaped and softened into character, with the middle tint very correctly, then make out all the parts of the shadows, with the tint driven bare; after this comes the middle tint for the several lights and gradations, which should be very nicely wrought up to character without touching any of the high lights which finish the first lay.

White Satin. — All whites should be painted on white grounds, laid with a good body of colour.

There are four degrees of colours in

the first lay to white satin. 1st. Fine white for the lights. 2nd. The first tint which is made of fine white and a little ivory black, mixed to a middle degree, between the white and the middle tint: this colour follows the white; it is with this you should shape the lights into character before you lay on any other.

The middle tint should be made of white, black, and a little Indian red. The shade tint should be made of the same colour as the middle tint, but with less white; next follows the reflects and finishing tints. Brown ochre mixed with the colour of the light is the most useful colour in general for all reflects in draperies that are produced from their own colours; there are but two reflecting tints wanted in general for draperies, one should be lighter than the middle tint, the other darker.

Blue satins.—Blue satin is made of Prussian blue and white: the best ground for blue is white for the lights and black and white for the shadows. The first

The first lay of colours for blue is divided into three degrees or tints. First make the middle tint of a beautiful azure: then mix the colour for the light about a middle degree between that and white—make the shade tint dark enough for the shadows in general—all the broad lights should be laid with plenty of colour, and shaped to character with the middle tint, before you lay on other colours; next follow with the rest of the middle tint, and then make out all the shadows. The shadows should be strengthened with ivory black and some of their own colour.

Velvet may be painted at once: the method is to make out the first lay with the middle tint and shade tint, on which lay the high lights with light touches, and finish the shadows in the same manner as those of satin; but the nearest imitation of velvet is produced by glazing, the method of which is to prepare a ground with such colours as will, when dry, bear out and support the glazing colour in its highest perfection. The

glazing colour is to be used with oil only, so that whatever ground it is laid upon, the whole may appear distinctly through it: remember to make the middle tint lighter in proportion to the glazing, because that will make it darker.

Scarlet and crimson.—A light yellow red, made of yellow ochre, light red, and white is the proper ground for scarlet; the shadows are Indian red, and the darker parts mixed with a very light black.

The second painting should be a little lighter than you intend the finishing colour, in proportion to the glazing, which will make it darker. The high lights are vermilion and white for white satin and velvet, and vermilion for cloth. The middle tint is vermilion, with a little lake or Indian red; the shade tint is made with Indian red and lake, with the addition of a little black in the darkest shadows. Their reflects are made with light red and vermilion; after it is dry, finish with glazing the whole with fine

lake, and improve the reflects and shadows ; the scarlet requires but a very thin glazing, and it is better to glaze the crimson twice over than lay too much at one painting.

Yellow.—There are the same number of tints in the yellow as in the white satin, and the method of using them is the same. The lights are made with chrome or king's yellow. The first tint is yellow ochre, changed with a little of the pearl tint, made with the dark shade and white ; the middle tint is a mixture of the yellow and brown ochre, softened with the pearl tint.

The shade tint is brown pink and brown ochre ; the reflects are yellow ochre, and sometimes in the warmer parts mixed with a little light red. The shadows are strengthened with brown pink and burnt umber. The method of painting silks is to make out the folds with the shade tint, and then fill them up in the lights with the middle tint. This should be done to your satisfaction before you add any other colours, and the stiffer the

middle tint is used the better the high lights may be laid upon it; the last part of the work is the finishing and strengthening the shadows with an obscure tint, such as will not catch the eye, and interrupt the beauty of the lights.

Black.—The method of painting black is very different from other colours, for the principal thing in them is to leave their lights clear and brilliant; in black it is to keep the shadows clear and transparent. The best ground for black is light red for the lights, and Indian red and a little black for the shadows. The finishing colours for the lights are black, white, and a little lake. The middle tint has less white and more lake and black: the shade tint is made of an equal quantity of lake and brown pink, with a very little black. Begin with the shade tint, and glaze over all the shadows with it; next lay in the darkest shadows with black and a little of the shade tint very correctly, after that fill up the whole breadth of lights with the middle tint only, and finish with the high lights.

Black is of a cold heavy nature, and always too strong for any other colour, therefore you should make an allowance in using it.

Linen.—The colours for linen are the same as those in white satin, except the first tint which is made of white, and a little blue instead of the black. In the dead colouring be very careful that the grounds are laid very white and broad in the lights. The shadows are made with black, white, and a little Indian red, like the middle tint of white satin. The second painting begins with glazing all the lights with a stiff pencil and fine white only, driven bare without using any oil. The shadows may be scumbled with poppy oil and some of the colour they were made of. This is the first lay on which you are to follow with the finishing colours directly. The middle tint of white satin is the best colour for the general hue of the shadows; with this and white in different degrees make out all the parts to character with free light touches, without softening; then with a

large long pointed pencil and fine white, lay the high lights very nicely with one stroke, after this comes the fine light blueish tint, which should be mixed light and laid in the tender gradations very sparingly and lightly, without filling them up. The first lay should be left clear and distinct. It is the overmixing and joining all the colours together which spoils the beauty of the character, therefore it is better to let it dry before we add the reflects and finishing tints.

In draperies all colours do not suit all sorts of persons. In mens' portraits we need only observe great truth and great force ; but in womens' there must also be charms, whatever beauty they have must appear in a fine light, and their blemishes must by some means or other be softened. A white, lively, and bright tint, ought never to be set off by a fine yellow, which would make it look like plaster, but rather by colours inclining to green, blue, or grey, or such others, as by their opposition may make the tint appear more fleshy than usual in fair women.

Dark women who have yellow enough in their tints to support the character of fleshiness, may very well have yellowish draperies, in order to bring down the yellow of their tints, and make them look the fresher.

OF PAINTING BACK GROUNDS.

In grounds two things are observable, the tone and the colour. The colour is to be considered in the same manner as those of draperies with respect to the head. The tone must be always different from the mass it supports, and of which it is the ground, that the objects coming upon it may not seem transparent, but solid and raised. The colour of the hair of the head usually determines the tone of the ground, and when the former is a bright chesnut, we are often embarrassed, unless assisted by means of a curtain, or some accident of the *claro-obscuro*, supposed to be behind, or unless the ground is a sky.

We must further observe that where a ground is neither curtain or landscape,

but is plain, or like a wall, it ought to be very much party coloured with almost imperceptible patches or stains, for, besides it being so in nature, the picture will look more grand.

The principal colours that are necessary for painting of back grounds, are white, black, Indian red, yellow and brown ochre, Prussian blue, and burnt umber, from which the eight principal tints are made as follows—1. Pearl is made of black, white, and a little Indian red. 2. Lead, of black and white, mixed to a dark lead colour. 3. Yellow, of a brown ochre and white. 4. Olive, of yellow ochre, Prussian blue and white. 5. Flesh, of Indian red and white, mixed to a middle tint. 6. Murrey, of Indian red, white, and a little black mixed to a kind of purple of a middle tint. 7. Stone, of white, umber, black, and Indian red. 8. Dark shade of black and Indian red. Here the lead tint serves for the blues, the flesh tint mixes agreeably with the lead, and the murrey is a very good blending colour, and of great use where

the olive is too strong, the umber, white, and dark shade, will produce a fine variety of stone colours ; the dark shade and umber, used plentifully with drying oil, make an excellent warm shadow colour. All the colours should be laid with drying oil only, because they mix and set the better with the softener. PROCESS :—the process of painting back grounds is divided into two parts, the first lay, and the finishing tints ; in the first lay begin from the shadowed side of the head, and paint the lights first ; then go on with the gradations and shadows, which should be done with a tool of middling stiffness in a sparing way, with the dark shades and white a little changed with those colours that will give it more of the required hue, but very near in regards to tone and strength.

The dark and warm shadows should be laid before the colours that join them, by means of the dark shade and umber, with drying oil.

The second part is to follow directly, while the first lay is wet with those tints

that are most proper to harmonize, and finish with. Begin with the lights first, accompanied with fine tender cold tints; from the lights go to the gradations and shadows, then soften and blend the whole with a long large hog tool. Most tints will sink and lose a little of their strength and beauty in drying. All grounds as walls, &c., should be finished at one painting, but if they want to be changed, glaze them with a little of the dark shade and drying oil, on which, with a few light touches of the colour that is wanting, you may improve their hue; the dark shadows may likewise be strengthened and improved by glazing after the figures are nearly finished, lest they should appear too strong.

Curtains should be dead coloured when you paint the ground with clean colors of a near hue to the intended curtain. The sky should be broken with the lead and the flesh tints. The murrey is of essential use in the grounds of distant objects, and the umber and dark shades in the near grounds; after all is painted,

go over the whole very lightly with the softener, which will make it look agreeably finished.

General rules for the painter, by Sir Joshua Reynolds.

For painting the flesh black.—blue, black, white, lake, carmine, *orpiment*, yellow ochre, ultramarine, and varnish.

To lay the palette.—First lay carmine and white in different degrees: Second, lay orpiment and white ditto: Third, lay blue-black, and white ditto.

The first sitting.—Make a mixture on the palette for expedition as near the siter's complexion as you can.

To preserve the colours fresh and clean in painting.—It must be done by laying on more colours, and not rubbing them in when they are once laid, and if it can be done, they should be laid just in their proper places at first, and not be touched again, because the freshness of the colours is tarnished, and lost by mixing, and jumbling them together, for there are certain colours which destroy

each other by the motion of the pencil when mixed to excess ; for it may be observed that not only is the brilliancy, as well as freshness of tints, considerably impaired by indiscriminate mixing and softening, but if the colours be too much worked about with the brush, the oil will always rise to the surface, and the performance will turn comparatively yellow in consequence.

Never give the least touch with your pencil until you have present in your mind a perfect idea of your future work.

Paint at the greatest possible distance from your sitter, and place the picture occasionally near to the sitter, or sometimes under him, so as to see both together.

In beautiful faces keep the whole circumference about the eye in a mezzotinto, as seen in the works of Guido, and the best of Carlo Maratti.

Endeavour to look at the subject or sitter before you as if it was a picture ; this will in some degree render it more easy to be copied.

In painting, consider the object before you, whatever it may be, as made out more by light and shadow than by lines.

A student should begin his career by a careful finishing and making out of the parts, a practice which will give him freedom and facility of hand; a bold and unfinished manner is generally the habit of old age.

ON PAINTING A HEAD.

Let those parts which turn or retire from the eye be of broken or mixed colours, as being less distinguished and nearer the borders.

Let all your shadows be of one colour, glaze them till they are so.

Use red colours in the shadows of the most delicate complexions, but with discretion. Contrive to have a screen with red or yellow colour on it to reflect the light on the sitter's face: avoid the chalk, the brick dust, and the charcoal, and think of a pearl and a ripe peach; avoid long continued lines in the eyes, and too many sharp ones.

Take care to give your figures a sweep or sway, with the outlines in waves, soft, and almost imperceptible against the back ground.

Never make the contour too coarse. Avoid also those outlines and lines which are equal, which make parallels, triangles, &c.

The parts which are nearest to the eye appear most enlightened, deeper shadowed, and better seen.

Keep broad lights and shadows, and also principal lights and shadows.

Where there is the deepest shadow, it is accompanied by the brightest lights.

Let nothing start out, or be too strong for its place.

Squareness has grandeur ; it gives firmness to the forms ; a serpentine line in comparison appears feeble and tottering.

The younger pupils are better taught by those who are in a small degree advanced in knowledge above themselves.

Landscape Painting.

LANDSCAPE painting includes all objects

presented to our view in a prospect of the country, and is commonly divided into the heroic or historical, and the rural or pastoral, of which all other styles are but mixtures.

The principal parts of landscapes are their openings or situations, accidents, skies, and clouds, offskips and mountains, verdure, rocks, grounds, terraces, buildings, water, fore-grounds, plants, trees, and figures.

Of the principal colours used in landscape painting.

The principal colours used in landscapes are flake white, white lead, or common white, yellow ochre, chrome yellow, king's yellow, burnt terra, sienna, brown ochre, brown pink, burnt umber, ivory black, Prussian blue, ultramarine, terra verte, lake, Indian red, and vermilion.

The colours necessary for dead colouring, are common white, yellow ochre, brown ochre, burnt umber, Indian red, ivory black, and Prussian blue.

For painting the sky.—Fine or flake

white, ultramarine, Prussian blue, yellow ochre, vermilion, lake, and Indian red.

PROGRESS OF THE PAINTING.

Sketch or rub in your design faintly with burnt umber, or burnt terra sienna, used with drying oil, and a little oil of turpentine, leaving the colour of the cloth for the lights; in doing this, leave no part of the shadows so dark as you intend the first lay, or dead colouring, which also must be lighter than the finishing colours.

The foliage of the trees is to be rubbed in, in a faint sort of scumbling, but the trunks and bodies must be in their proper shapes, with their breadths of light and shadow. All buildings should be done in the same manner, leaving the colour of the cloth for their lights. The figures in the fore ground may also be sketched, if determined on, in the same manner, and then left to dry. Landscapes are generally began about the centre of the piece. Paint the sky first, and gradually advance from the distant objects to the

fore ground: the back grounds of all objects should be painted first, before the object itself: all the parts of each group, as trees, buildings, &c., should be painted with the group they belong to. The greatest art in dead colouring is to find the two colours which serve for the ground of shadows in general, and the method of using them with the lights; the first is the dark shade, with a little lake in it: the other is burnt umber only, these should be a little changed to the natural hue of the objects, and then laid on with drying oil in a kind of thin glazing. Both these colours mix agreeably with all the lights, but should be laid before them. The sky should be laid with a good body of colour, and left with a faint resemblance to the principal clouds; the distances should be made out faint and obscurely, with the dark shades and some of their lights in different degrees. All the grounds of the trees should be laid or rubbed in faintly, just to give an idea of their shapes and shadows. In painting the lights it is

better to incline to the middle tint than to the very high lights. After this, go over the whole with a sweetener very lightly, which will soften and mix the colours for finishing.

SECOND PAINTING.

Begin with the sky, and lay in all the azure and colours of the horizon, then soften them, after that lay in the general tint of the clouds, and finish on it with the high lights, and the other tints that are wanting with light tender touches, then soften the whole with a sweetener very lightly. The finishing of the sky should be done at one painting, as the tender character of the clouds will not do so well as when the whole is wet. The stiffer the azure and colours of the horizon are laid, the better the clouds may be painted upon them.

The greatest distances are chiefly made with the colour of the sky; as they grow nearer and darker, glaze and scumble the parts very thin, with such glazing shadow colours as come nearest to the general

hue of the group the objects are in. The glazing should be of a darkish hue, and the first painting, or dead colour, should be seen through it distinctly; on this lay or ground add the finishing colours. In painting the finishing lights of the same, you must be careful not to spoil the glazing; therefore, be very exact in making those colours on the palette and lay them with light free touches. Of glazing colours the most useful are, lake, terre-verte, Prussian blue, brown pink, and burnt terra sienna. The more you manage them like Indian ink, and the more distinctly you leave them, the better their transparent beauty will appear, if you do it with good drying oil. After these colours, burnt umber is a very good glazing warm brown, and is of great use in the broken grounds and nearest parts, but the most agreeable colour for the darkest shadows is the dark shade improved with lake. It is a fine warm shade, mixes harmoniously with all the lights, as well as the shadows, and is an excellent colour in the trunks and bodies of trees, and buildings.

Make out all the ground of the objects with such glazing shadow colours as seem nearest to the natural hue of the object in that situation, but as the principal glazing colours are often too strong and glaring, they should be a little changed and softened with such colours as are of a near resemblance to themselves and the objects ; thus, if it is in the distances, the terre-verte and the azure, which are the principal glazing colours, may be improved and made lighter with some of the sky tints, and, as the distance comes nearer, with the purple. In the middle group the terre-verte and the Prussian blue may be changed with some of the green tints, such as are made without white, for white is the destruction of all glazing colours : as you approach the first group there is less occasion for changing them, but the fore ground and its objects require all the strength and force of glazing which the colours are capable of producing ; after this glazing ground follow with strengthening the same in the shadows and darkest

places, in such manner as will seem easy to finish, which is the first lay of the second painting.

The colours that come next for finishing are in the degree of middle tints: these should be carefully laid over the greatest breadth of lights, in such a manner as not to spoil and cover too much of the glazing; do it with a good body of colour, as stiff as the pencil can agreeably manage. The colours of the middle tint should be of a clean beautiful hue; by this method it will be easy to finish all the second painting down from the sky, through the middle group: as you come to the first group, where all the objects should be perfectly finished, finish their under or more distant parts before you paint any of the other which appear nearer. Observe this method down to the last and nearest objects of the picture, and where it so happens that painting one tree over another does not please, forbear the second until the first is dry; the near trees of different colours will do better if you let the under

parts dry before you add the finishing colours.

THIRD AND LAST PAINTING.

If necessary, lay the least quantity of oil that can be with a stump tool or pencil, proportioned to the place that is to be oiled, so as to oil no more than is wanted, then wipe the whole with a piece of silk handkerchief.

In finishing any objects it is best to use a great variety of tints, very nearly of the same colour, but particularly when finishing trees. This gives a richness to the colouring, and produces harmony. The greens will fade and grow darker; therefore it is highly necessary to improve and force them by exaggerating the lights and making an allowance in using them, so much the lighter; for the same reason take care not to overcharge and spoil the beauty of the glazing. The method of painting near trees is to make the first lay very near to nature, though not quite so dark, but more in the degree of a middle tint, and follow it with strength-

ening the shadows, then the middle tints, and last of all lay the high lights and finishing colours; all this cannot be done properly at one painting, therefore it is best to do no more than the first lay with the faint shadows and leave it to dry. Then begin with improving the middle tints and shadows, and leave them to dry.

The third and last work is adding all the lights and finishing colours in the best manner you are able; this method of leaving the parts to dry separately, not only makes the whole much easier and more agreeable, but leaves the colours in the greatest perfection, because most of the work may be done with scumbling and glazing, and some parts without oiling. The lights also may be laid with a better body of colour, which will not be mixed or spoiled with the wet ground.

The figures in the landscape are the last work in the picture; those in the fore-ground should be done first, and those in the distances next, for after the

figures in the first and farthest group are painted, it will be much easier to find the proportions of those in the middle part of the picture; the shadows of the figures should be of the same hue or colour with those of the group or place they are in.

The following rules and cautions should be carefully attended to by the student: If a tint be required while he is at work on a picture, different from any on his palette, it is better to mingle the colours which compose it on the palette with a knife than with a pencil, as the pencil always retains more of one colour than another, when it is used to incorporate them together, one pencil should always be kept to one colour, otherwise the colours will never appear fresh. Colours should never be teased, that is mixed too much, or, when instead of being laid on the canvass at once they are too much worked about with the pencil, a proper allowance must always be made for that gloss and brilliancy which oil colours possess when wet.

The decay of colours is, in a great measure, the consequence of too great a quantity of oil. The parts of a picture which first begin to fade are the darker colours, the glazing, and where the colour is thin, the lights stand much longer.

It is always proper to permit a first coat of colour to be sufficiently dry before a second is applied.

To ascertain when an oil painting is dry, it must be breathed upon pretty strongly, and if it take the breath it is dry.

The palette and pencils when laid by should be constantly cleaned with spirits or oil of turpentine.

The oils with which the colours are mixed are of more importance in the art than is generally imagined: from their quality and their intimate mixture with the colour by which they form, as it were a part of the colour itself, they cannot but have a very great influence on the success of the piece. Those most in use are linseed oil, nut oil, and poppy oil. Linseed oil generally injures light colours;

its use therefore is, or should be, confined to the darker ones. Nut oil is in more general use; it is more transparent than linseed oil, of a finer quality, works smoother, and is not so liable to change the colours. Poppy oil is generally preferred to the two others; it is also clearer than nut oil. For pictures painted in haste, and to preserve others from the injuries arising from the dampness of the weather, drying oil is sometimes used; it should, however, be used with caution, and that only when indispensable, as those subjects where it has been admitted, are generally found in a short time to have the appearance of old and decayed paintings.

Recipes, &c.

TO PREPARE CLOTH, OR CANVAS.

It is first strained tightly upon a frame, then washed with a thin glue; when dry it is painted with a coat of oil colour, made of white lead, red led, and linseed oil and turpentine, and afterwards with a

second coat in which the red lead is omitted, and sugar of lead substituted. It is not particular what tint it is of, provided it is rather light than dark. Portrait painters choose a very thin priming, and many modern artists do not prime their cloths at all.

TO MAKE MEGILPH.

To one third best boiled oil put two thirds mastick varnish, stir it till it comes to the consistency of a jelly, let it stand a few days and it will be fit for use. This will be found a most useful composition for painters in general, as it not only makes a fine clear varnish for oil pictures, but dries quickly in a warm room, and will also mix with any colour to paint with; and it will never crack as many varnishes do.

TO CLEAN PICTURES.

1st. Method.—Having taken the picture out of the frame take a clean towel, and making it quite wet, lay it on the face of your picture, sprinkling it from time

to time with clear soft water; let it remain wet for two or three days, take the cloth off and renew it with a fresh one, after wiping your picture with a clean wet sponge, repeat the process till you find all the dirt soaked out of your picture, then wash it well with a soft sponge, and let it be quite dry; rub it with some clear nut or linseed oil, and it will look as well as when fresh done.

2nd.—Clean your picture well with a sponge dipped in warm beer, let it dry, and wash it with liquor of the finest gum dragon, steeped or dissolved in clear water.

3rd.—If a picture be varnished and discoloured take a peice of cotton wool dipped in linseed oil, and then rub over the surface of the picture, wipe it clean off, and then use another peice of cotton wool; dipped in sweet spirits of nitre; rub it down the picture, and use a fresh peice every time, till the whole has been gone over; be cautions never to use the cotton twice. It may be desirable to try any common picture first by way of experiment.

**TRANSFERRING OLD PAINTINGS TO
NEW CANVAS.**

Let the decayed picture be cleaned of all grease that may be on its surface, by rubbing it very gently with crum of stale bread, and then wiping it with a very soft linen cloth. It must then be laid with the face downwards on a smooth table, covered with fan paper, or the Indian paper, and the cloth on the reverse must be well soaked with boiling water spread upon it with a sponge until it is soft and pliable. Turn the picture with the face upwards and stretch it evenly on the table ; pin it down with nails at the edges.

Having melted a quantity of glue, and strained it through a flannel cloth, spread part of it, when a little stiffened, on a linen cloth of the size of the painting ; and when this is set and dry, lay another coat over it—when this has become stiff, spread some of the glue, moderately heated, over the face of the picture, and lay over it the linen cloth already prepared in the most even mannner, and nail it

down to the picture and table. Then expose the whole to the heat of the sun, where it may be secure from rain, till the glue is dry and hard—than remove it from the table. Turn the picture with face downwards—let it be nailed as before; raise round its edges a border of wax, forming a kind of shallow trough with the surface of the picture, into which pour a corroding fluid, as oil of vitriol, or spirits of salts, (the last is to be preferred;) diluted to such a degree, determined by previous trials, that it may destroy the thread of the canvas without discoloring it. When it has answered the purpose, drain it off through a passage made in the wax border, and wash by repeatedly pouring fresh water on the cloth; the threads of the cloth must then be carefully picked out, till the whole be taken away, thus freed from the cloth, must be well washed with water and sponge, and left to dry.

In the meantime prepare a new peice of canvas, and having spread some hot glue, melted with a little brandy or spirits of

wine, over the reverse of the painting, lay the new canvas while the glue is hot, and compress them together with plates of lead, or marble. When the glue is set, remove the weights, let the cloth remain till the glue has become hard and dry, then the whole must be again turned, and the border of wax replaced; the linen cloth must be destroyed as before; the painting must then be freed from the glue by washing it with hot water and a sponge. The painting may then be varnished, and if the process has been well conducted, it will be transferred in a perfect state.

The Art of Drawing and Sketching from Nature.

DRAWING forms so elegant and agreeable an amusement for leisure hours, and has so wide a range of general utility that it cannot fail to be attractive to a well formed mind. It is equally adapted to both sexes; and whether it is employed in embodying the forms of fancy, or delineating the beauties of nature, and the inventions of art, it never fails to be a source of amusement: it is the basis of painting, designing, sculpture, architecture, engraving, &c. and most of those arts that are the offspring of fancy, and that embellish civilized life.

IMPLEMENTS AND MATERIALS USED IN DRAWING.

Drawing Boards are used to fix the paper upon; they may be made of any

D

wood that will not warp, or any convenient size; about two feet by eighteen inches is about the best; it must be smooth on the surface and perfectly square; upon this the drawing-paper must be fixed. Wet the paper well with a sponge on both sides, lay it upon the board, and turning up the edges about half an inch run a little good paste or glue all round on the under side, and press the paper down upon the board with a cloth; it is then left to dry in the air; the paper which had expanded and blistered when wet will strain quite flat and tight, and be much better for drawing upon than when loose. There are some drawing boards which look much neater, made with a frame and moveable panel, upon which the paper is put wet, and then forced into the frame and confined by wedges at the back. These drawing boards may be bought at most colour shops. A flat rule, called a T square, is requisite, which is used with the drawing boards; the short end, called the stock, is applied to the edge of the board; the

figures in the first and farthest group are painted, it will be much easier to find the proportions of those in the middle part of the picture; the shadows of the figures should be of the same hue or colour with those of the group or place they are in.

The following rules and cautions should be carefully attended to by the student: If a tint be required while he is at work on a picture, different from any on his palette, it is better to mingle the colours which compose it on the palette with a knife than with a pencil, as the pencil always retains more of one colour than another, when it is used to incorporate them together, one pencil should always be kept to one colour, otherwise the colours will never appear fresh. Colours should never be teased, that is mixed too much, or, when instead of being laid on the canvass at once they are too much worked about with the pencil, a proper allowance must always be made for that gloss and brilliancy which oil colours possess when wet.

The decay of colours is, in a great measure, the consequence of too great a quantity of oil. The parts of a picture which first begin to fade are the darker colours, the glazing, and where the colour is thin, the lights stand much longer.

It is always proper to permit a first coat of colour to be sufficiently dry before a second is applied.

To ascertain when an oil painting is dry, it must be breathed upon pretty strongly, and if it take the breath it is dry.

The palette and pencils when laid by should be constantly cleaned with spirits or oil of turpentine.

The oils with which the colours are mixed are of more importance in the art than is generally imagined: from their quality and their intimate mixture with the colour by which they form, as it were a part of the colour itself, they cannot but have a very great influence on the success of the piece. Those most in use are linseed oil, nut oil, and poppy oil. Linseed oil generally injures light colours;

its use therefore is, or should be, confined to the darker ones. Nut oil is in more general use; it is more transparent than linseed oil, of a finer quality, works smoother, and is not so liable to change the colours. Poppy oil is generally preferred to the two others; it is also clearer than nut oil. For pictures painted in haste, and to preserve others from the injuries arising from the dampness of the weather, drying oil is sometimes used; it should, however, be used with caution, and that only when indispensable, as those subjects where it has been admitted, are generally found in a short time to have the appearance of old and decayed paintings.

Recipes, &c.

TO PREPARE CLOTH, OR CANVAS.

It is first strained tightly upon a frame, then washed with a thin glue; when dry it is painted with a coat of oil colour, made of white lead, red led, and linseed oil and turpentine, and afterwards with a

second coat in which the red lead is omitted, and sugar of lead substituted. It is not particular what tint it is of, provided it is rather light than dark. Portrait painters choose a very thin priming, and many modern artists do not prime their cloths at all.

TO MAKE MEGILPH.

To one third best boiled oil put two thirds mastick varnish, stir it till it comes to the consistency of a jelly, let it stand a few days and it will be fit for use. This will be found a most useful composition for painters in general, as it not only makes a fine clear varnish for oil pictures, but dries quickly in a warm room, and will also mix with any colour to paint with; and it will never crack as many varnishes do.

TO CLEAN PICTURES.

1st. Method.—Having taken the picture out of the frame take a clean towel, and making it quite wet, lay it on the face of your picture, sprinkling it from time

to time with clear soft water; let it remain wet for two or three days, take the cloth off and renew it with a fresh one, after wiping your picture with a clean wet sponge, repeat the process till you find all the dirt soaked out of your picture, then wash it well with a soft sponge, and let it be quite dry; rub it with some clear nut or linseed oil, and it will look as well as when fresh done.

2nd.—Clean your picture well with a sponge dipped in warm beer, let it dry, and wash it with liquor of the finest gum dragon, steeped or dissolved in clear water.

3rd.—If a picture be varnished and discoloured take a peice of cotton wool dipped in linseed oil, and then rub over the surface of the picture, wipe it clean off, and then use another peice of cotton wool; dipped in sweet spirits of nitre; rub it down the picture, and use a fresh peice every time, till the whole has been gone over; be cautions never to use the cotton twice. It may be desirable to try any common picture first by way of experiment.

**TRANSFERRING OLD PAINTINGS TO
NEW CANVAS.**

Let the decayed picture be cleaned of all grease that may be on its surface, by rubbing it very gently with crum of stale bread, and then wiping it with a very soft linen cloth. It must then be laid with the face downwards on a smooth table, covered with fan paper, or the Indian paper, and the cloth on the reverse must be well soaked with boiling water spread upon it with a sponge until it is soft and pliable. Turn the picture with the face upwards and stretch it evenly on the table; pin it down with nails at the edges.

Having melted a quantity of glue, and strained it through a flannel cloth, spread part of it, when a little stiffened, on a linen cloth of the size of the painting; and when this is set and dry, lay another coat over it—when this has become stiff, spread some of the glue, moderately heated, over the face of the picture, and lay over it the linen cloth already prepared in the most even manner, and nail it

down to the picture and table. Then expose the whole to the heat of the sun, where it may be secure from rain, till the glue is dry and hard—than remove it from the table. Turn the picture with face downwards—let it be nailed as before; raise round its edges a border of wax, forming a kind of shallow trough with the surface of the picture, into which pour a corroding fluid, as oil of vitriol, or spirits of salts, (the last is to be preferred;) diluted to such a degree, determined by previous trials, that it may destroy the thread of the canvas without discoloring it. When it has answered the purpose, drain it off through a passage made in the wax border, and wash by repeatedly pouring fresh water on the cloth; the threads of the cloth must then be carefully picked out, till the whole be taken away, thus freed from the cloth, must be well washed with water and sponge, and left to dry.

In the meantime prepare a new peice of canvas, and having spread some hot glue, melted with a little brandy or spirits of

wine, over the reverse of the painting, lay the new canvas while the glue is hot, and compress them together with plates of lead, or marble. When the glue is set, remove the weights; let the cloth remain till the glue has become hard and dry, then the whole must be again turned, and the border of wax replaced; the linen cloth must be destroyed as before; the painting must then be freed from the glue by washing it with hot water and a sponge. The painting may then be varnished, and if the process has been well conducted, it will be transferred in a perfect state.

The Art of Drawing and Sketching from Nature.

DRAWING forms so elegant and agreeable an amusement for leisure hours, and has so wide a range of general utility that it cannot fail to be attractive to a well formed mind. It is equally adapted to both sexes; and whether it is employed in embodying the forms of fancy, or delineating the beauties of nature, and the inventions of art, it never fails to be a source of amusement: it is the basis of painting, designing, sculpture, architecture, engraving, &c. and most of those arts that are the offspring of fancy, and that embellish civilized life.

IMPLEMENTS AND MATERIALS USED IN DRAWING.

Drawing Boards are used to fix the paper upon; they may be made of any

D

the medium pencil is best for drawing perspective. The wood should be carefully cut from its point, and the lead sharpened by being gently rubbed on a file, which produces a better point than can be formed with a knife. India rubber or a clean crumb of bread to take out lines incorrectly drawn is necessary.

Paper may be purchased of all qualities for beginners: it is sufficient for it to be what is called "hard;" that is, it must bear to be written upon with pen and ink. Very great care is requisite in the making of drawing paper, that the surface may be perfectly smooth, equally sized, and that no chemical ingredient be employed, which can by possibility injure the exact tint of colour which the painter may wash over it; it is requisite also, that a long exposure to light and air should not turn it yellow. Its various names, dimensions, and average price per sheet, are as follows, in considering which, it may be observed, that drawing papers are made of a thickness in proportion to their respective sizes:—

	In.	In.	Per Sheet.	
			s.	d.
Demy, measures	20	by 15	— 0	2
Medium, do.	22	— 17	— 0	3
Royal, do.	24	— 19	— 0	4
Super Royal, do.	27	— 19	— 0	5
Imperial, do.	13	— 21	— 0	6
Columbian, do.	34	— 23	— 0	9
Atlas, do.	33	— 26	— 0	9
Double Elephant, do.	40	— 26	— 1	0
Antiquarian, do.	52	— 31	— 3	6
Extra large, do.	56	— 40	— 4	6

These implements will be sufficient until a knowledge of the art suggests the necessity for a case of mathematical instruments.

GENERAL INSTRUCTIONS.

Thus furnished with materials and implements, the student must confine himself to the copying of single subjects, and by no means attempt groups of objects, as that will confound his ideas. It is absolutely necessary to advance progressively, commencing with the figures of arches, circles, ovals, cones, and squares, all which, except the latter, have an

evident resemblance to many of the forms of nature. Trees should also be drawn singly, carefully observing the nature of the bark, the characteristics of the trunk, the form of the leaves, &c., so that an observer shall, upon the first inspection of the drawing, pronounce whether it is an oak, an elm, or a poplar, &c. Animals may be the next object of the student's attention; a knowledge of the forms of which will be best obtained by copying some good drawings and prints; he may then proceed to the human figure, commencing with drawing the eye, mouth, nose, teeth, &c., separately, till he is perfect, when the whole figure may be attempted. In order to do so effectually, it is necessary to imitate the parts already mentioned from good drawings, with black lead or black chalk: the shading will be better explained by the drawing copied from than by any directions.

The pentagraph is an useful instrument for copying a drawing upon an enlarged scale; it is rather expensive for ordinary students; it may be effected almost as

well by the following simple means:— Take a sheet of Bristol board, cut in it an aperture, according to the size of the print or drawing to be copied, then, near the edge of the aperture, divide the top, base and sides, into half-inch measurements, then, with a needle, pass some fine thread through the various marks, from side to side and from top to bottom, taking care that it always issues from the same side of the card; number the threads on the base from the left, and from the base upwards on each side. Of whatever size the drawing may be required it is necessary to determine the proportions, as one, two, or three inches for each half-inch square of the card; thus the boundary line of the drawing being ascertained, measure off the squares in number agreeing with those of the card, and rule the lines horizontally and perpendicularly true, just to be visible, then sketch the outline of the subject, observing in what squares or lines any particular object appears when the threaded card is placed close to the print or drawing, and imitate

them in the corresponding squares and lines of the large drawing.

DRAWING THE FIGURE.

The study of the human figure has always been considered by artists as the most important part of the art. It is the most difficult, and is considered by many as contributing the most of any to general improvement.

The study of the human figure includes all the finest principles of the art, and when the eye of the student has been accustomed to copy faithfully all the minute circumstances which constitute the character of a figure, and to attend to the innumerable beauties, and graceful forms which it presents, he will be better qualified to pursue with advantage every other branch of the fine arts. In order to acquire a knowledge of the face, begin with drawing the features separately, placing the copy at such a distance as the eye may measure both without moving the head. Sketch in the first outline very light, and in rubbing it out leave

faint traces of the first sketch. The positions and actions of the hands and feet are so various that a knowledge of them can only be obtained by great application and practice, carefully imitating such postures, both in hands and feet, as are found in good prints or drawings. If time or circumstances permit, they may be first studied from casts conveniently placed on the table. In drawing from a plaster figure the eye will easily discover the general light and shade: the mass of light should be kept broad and be well attended to before the smaller parts are divided. The outline should be exceedingly faint in such parts as receive the light: all the parts of a human figure are composed of curved surfaces, no straight lines are ever admissible, but every line should have a graceful turn; it is this circumstance particularly that occasions the study of the figure to give so much freedom in drawing. Care should be taken that no lines ever cross each other at right angles, which gives a disagreeable net-like appearance; neither should

the crossings be too oblique, as then they appear confused; a proper medium will be acquired by the study of good drawings or prints. In learning to draw it is of more importance than is generally supposed to copy from the finest works only. The way to avoid mediocrity is by the study and imitation of beautiful productions.

Having copied frequently the parts of a face the student may proceed to the entire head, drawing first a front view, then a profile, a three quarter, and so on. by these exercises he will have acquired some facility in handling his pencil. He may then proceed to the drawing of the whole figure.

The proportions of the human figure. The rules for drawing a head.

A perfect oval should be formed through which a perpendicular line is drawn in the middle, and across the centre of this a diameter line from one side of the oval to the other: on these all the features of the face are to be drawn according to the

following rules :—the perpendicular must be divided into four equal parts, 1st. from the crown of the head to the top of the forehead : 2nd. from the top of the forehead to the eye : 3rd. from the eyes to the bottom of the nose : 4th. from thence to the bottom of the chin.

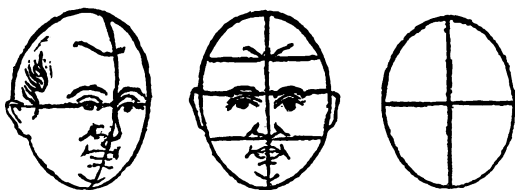

The breadth of the face is supposed the length of five eyes.

This is to be understood in a full front face only : these proportions vary in different men as to length and shape, but in a well proportioned face are nearly right, and should be strictly observed. Most artists begin the drawing with the nose, that being the centre, and then proceed with the other features, observing

that the top of the ear is to rise parallel to the eyebrows ; the eye is to be placed so as to leave exactly the length of one eye between them.

The proportions of the figure.

The height of a figure is eight times that of its head ; half its height is at the lower part of the body ; a quarter of its height is at the knee. The division of the human figure can be readily understood by the following method : draw a perpendicular line, then divide it into eight equal parts, give one for the head, a second for the breast, a third for the centre of the abdomen, a fourth for the lower portion of the body, a fifth for the middle of the thigh, a sixth just below the knee, a seventh just beneath the calf of leg, and the eight part to the sole of the foot.

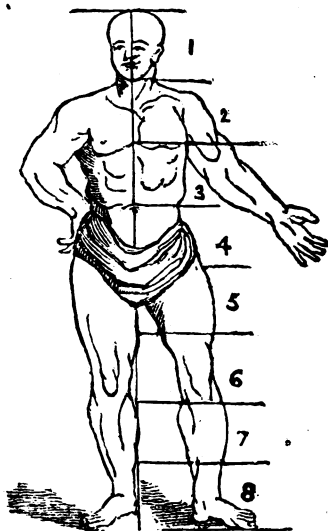

The shoulders are two heads in width; the elbow is a head and a half from the shoulder; and the arm, with straightened fingers is three heads and a half from the shoulder; the hands are double their breadth in length, and when extended they are exactly the length of the face. The proportions of children are generally as follows: three heads in length from the crown of the head to the

groin, from thence to the sole of the foot two, one head and a half between the shoulders, one of the body, between the hips and arm-pits. It is, perhaps, impossible to draw a perfectly beautiful figure from any one person, the most skilful painters, aware of this fact, have composed their finest works from different subjects. To draw a figure correctly, the intended length should be marked, and all the preceeding measures strictly adhered to, beginning the sketch on the left hand with the head, following with the shoulders, the trunk, the leg most in action, then the other, finishing with the arms, and making the outline perfect before any part is finished.

OF LANDSCAPE DRAWING AND SKETCHING FROM NATURE.

It is absolutely necessary to understand the rules of perspective before the student attempts to copy a drawing or print, for although the heights of trees, bushes, hills, &c. &c. vary greatly, yet there is a general and palpable delusion in the rela-

tive proportions as they retire from the eye. Besides, if a building intervenes the want of truth in this particular becomes instantly obvious.

When the student has studied perspective (of which we shall treat in another part of this work) he may proceed to copy good drawings or prints with the black-lead pencil. He should at the same time draw detached objects till their forms are perfectly and correctly obtained. Having accomplished this point, groups will be more easily understood and copied: nothing will contribute more towards obtaining correctness in drawing than a free use of the black lead pencil, which should not be held too near the points, nor should the rule and compasses be employed, except in making admeasurements and drawings of architecture. Black lead pencil drawings can be finished up to considerable neatness, or to powerful effect. The pencil should be of the best Cumberland lead, and it should not be cut to a point after the first time, until the exhaustion of the lead

renders it absolutely necessary. The blunted pencil by being *waved* upon a form is capable of giving to it any degree of shade; the process is passing the pencil backwards and forwards in zig zags of convenient length, in such manner as not to repeat one marking on another, but so close as to produce an equality of tone over the space required. This uniform tone is called the grain, and by judicious waving in different directions any gradations of strength may be communicated. The point of the pencil is destructive to the effect alluded to, because it will give a line which repetition will only render more offensive.

The clearness of this grain produced on masses which have been previously drawn with a tender outline, is essential to the preservation of distances by gradations of power. It is the perfection of this kind of drawing to effect as much as possible, independently of outline or the evidence of it, in the process of waving in the masses. After having thus gained some knowledge, it will next be proper

to study after nature. As to perfection it can only be expected from long practice and perseverance, and for those who have an inclination for Landscape, above all things, to take the proper method for beginning it well.

SKETCHING FROM NATURE.

After the introductory rules of perspective have been mastered, and some progress has been made in delineating single and simple objects, the lessons of the student may very profitably be varied by a few attempts at sketching from nature. When a few varieties of subjects shall have been sketched, let the character of the lines be examined, to ascertain if they express the intention; to adopt such as have meaning, and to reject those which may be vague. Improvement never fails to attend such investigations; they become necessary since there can be no clear directions how a student should express with a pencil the complicated forms which nature presents to the view. All persons who sketch have adopted some mode of

their own, which habit has improved to various degrees of perfection. No one can have any just motive for imitating the style of another. The delineation of characteristic forms, with freedom and correctness, is a power not to be obtained by chance or by purchase, but by patient assiduity and judicious observation in frequent appeals to nature. It is always beneficial to become acquainted with any successful means by which others have attained excellence; but, as we have said before, every one ought, with diligence, to form a correct style of his own, and the nearer he approaches nature, in his representations, the higher is his excellence as an artist, and the more his productions will be appreciated. Some artists have designed after nature and quite finished those parts they had chosen on the spot, but without adding any colour to them: others have only drawn the outlines of objects, and slightly washed them in colours.

In examining a natural scene it may be observed, that all is void of outline, and

that every distinct object is relieved from that which adjoins it by a separation of light and shade, or other accidental peculiarity. In sketching, nevertheless, outline is adopted because it is the only means of obtaining a knowledge of the forms, and the simplest means of detaching them; but immediately after the student shall have become acquainted with the form of an object, it must be considered as having been operated upon by light, and the portion of outline which is next to the source of illumination, should be more tenderly defined than those parts which may be differently situated. Now this attention to light and shade in outline is preparatory to the more correct representation of nature, and the student ought to be satisfied that in whatever may be attempted time will not be lost in the endeavour to preserve the proper lights and shades; at first these undertakings should be of the simplest kinds: there is no production of bountiful nature that is not worthy of consideration, or that is incapable of yielding its reward to

a careful student : suppose it to be the leaf of a willow ; the elongated curve, with its smooth edges, and tapering vein down the centre, offer practice for command of hand in conveying the imitative lines to the paper, while a perfect knowledge of the character of the leaf is at the same time acquired. Let the student select from any tree, a small sprig having three or four leaves, and place it naturally in front of the drawing-board, as an object for study. Then examine attentively the position of each leaf, its graceful connection with the stem, and the insertion of the leaf-stalk into the wood. Such a tranquil investigation of the distinct parts of which the object is composed has been observed to lessen a confusion of ideas that takes possession of a juvenile student ; when as a whole it has been contemplated, or rather glanced at, with a fear of not being able to imitate what was seen ; nothing can be done while the eye is roving over the object ; no beginning, no end appears. Let the mind be brought to act upon what is required ; direct the

attention to that part which may be deemed the principal, or the most conspicuous leaf upon the sprig. Consider its position; observe if it project to the front or laterally; when all that relates to the principal leaf has been thought upon, the part on which to commence is suggested to the mind, and the hand imitates that to which the eye is studiously directed.

The first leaf being lightly sketched, it is easy to add an adjoining leaf, and so on till all be on the paper. The student should then look over every part, to detect any deviation from the forms of the original. If this examination and correction produce likeness, let the lines and characteristic marks be drawn in with a firmer or bolder pencil; very often the most trifling touch, in addition, will communicate what seemed to be required to give character to a leaf. A weaker line on the side which meets the light, and the stronger line confined to those parts which may be opposed to the light, materially assist in giving satisfaction, from the spirit which such sketch-

ing imparts, The student is at all times advised to be sparing in the use of Indian-rubber ; at times it is useful, but generally it is brought into action because thought had not previously been sufficiently employed. The following cut may serve to convey an idea of what is intended by the preceding remarks.

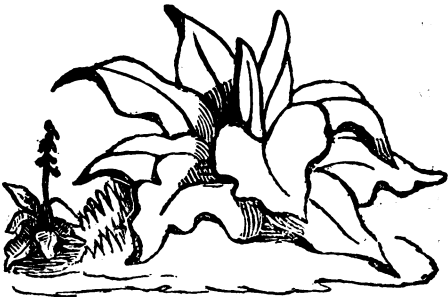

The light is from the right, on which the tenderest lines are preserved, while those opposed to the light receive a more powerful marking with occasional increase of force. Such studies as these should be made in the fields, where there is not a hedgerow but presents numberless subjects, each with its form and characteristic touch—the plantain, the dock, the

thistle, the fern, the briar, and the thorn. The advantages to be derived from consulting these objects where they grow must be obvious to every one who will admit that originals are superior to copies, which all prints and drawings are. The student can as easily copy from nature as from an imitation of nature. The only method by which to produce a satisfaction—that stimulates to exertion in drawing, is to study and copy carefully the characteristic forms of objects as nature presents them. At all times give a boldness of line with a pencil rather soft, because it can be used with more freedom, and will communicate more spirit than a hard or fine-pointed pencil.

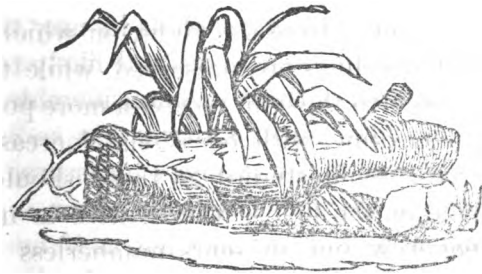

The above is a combination of rural objects that may frequently be observed on the road-sides. These are simple subjects, but they possess character, and such as artists avail themselves of as accessories in landscape painting. These may appear tedious to the ambitious student, but they teach how essential patience is to the obtaining of a correct sketch. It is by searching for the various beauties and carefully copying them into the sketch-book that the characters can be appreciated, and it is by reference to those judiciously selected transcripts from nature that the remembrance of their peculiarities is preserved.

The student, under the guidance of his own taste, should select some assemblage of ordinary objects, such as he may think agreeable in themselves and likely to be represented without any considerable difficulty. He must observe that an artist rarely ever takes an object in its broadest and most regular form: he never represents a house, for instance, as if he had taken up his position right in front of it,

as an architect would do; nor would he paint a row of trees at a right angle to his own position, seeing that the effect of such representations would be tame and formal. A house, particularly, should always be viewed from a point a little aside from the front, so as to bring in as many of its angularities as possible.



For an early lesson in sketching from nature it is enough that the objects be outlined; to fill in details and give the full effect of light and shade must be left to a future period in the career of a young artist. Full instructions will be given in the course of this book under "Tinting" and "Painting in Water Colours."

The station for a sketch being selected, the student is recommended to hold up the sketch-book in front with one eye closed, in order to determine how much of the scene is to be transcribed; the further off the book is held the less of the subject will be covered. When the extent of the scene is arranged the book may be gently lowered, and a few dots made on the top margin merely to point out the relative situations of particular features. When these or more dots for guide have been placed, examine their relative distances, and compare them with the objects by holding the sketch-book out in front so as to see the agreement between them over the margin. To arrange these particulars well at first, will save much trouble in obliterating falsely drawn lines. In a few studies the student will discover that by beginning with a cut point to the pencil it gradually wears away and gives an increasing thickness of line; this is often very advantageous, for as the sketching advances to the foreground the bolder lines of the pencil con-

tribute to the separation of parts, to regulate distances, and give a more spirited effect to the subject. Many advantages arise from two or three students sketching the same scenes in company, for various valuable remarks are thereby elicited, tending to mutual benefit. The sketch-book should be preserved complete as containing records of advance in judgment and correctness of delineation.

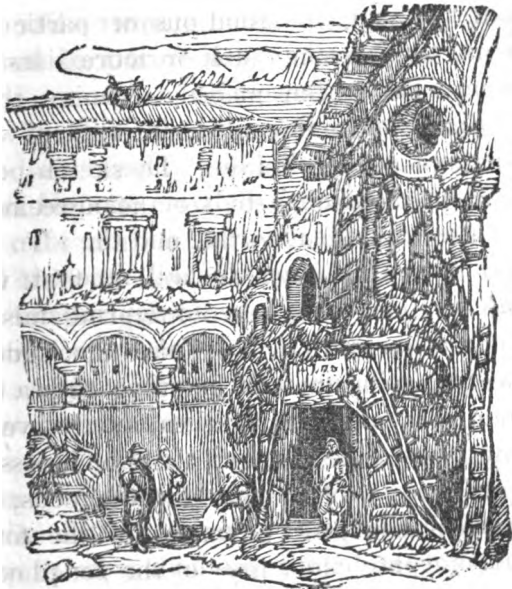

If it be asked which is the most proper time for these studies? the answer is that nature should be studied at all times, because she is to be represented at all seasons.

But as we cannot see or observe every thing, it is requisite to make use of other men's studies, and to look upon them as if they were our own, and copy the works of those who have excelled in any kind in order to acquire a good manner—like the bees, which gather their variety of honey from different flowers.

Sir Joshua Reynolds, in one of his lectures observes: — “There is one precept in which I shall be opposed only by the vain, the ignorant, and the idle. I am not afraid that I shall repeat it too often. You must have no dependence on your own genius. If you have great talents, industry will improve them; if you have moderate abilities, industry will supply their deficiency.”

“Though a man cannot at all times and in all places paint or draw, yet the mind can prepare itself by laying in proper

materials, at all times and in all places; whether at home or abroad, in the streets or in the fields, every object that presents itself is to him a lesson."

Recipes, &c.

TO FIX BLACK LEAD PENCIL

DRAWINGS.

DISSOLVE a small quantity of isinglass, and dilute it with warm water till so thin that when spread upon paper and dry it shall be free from those sparkling particles which never fail to appear if too thick. Take a broad, flat camel-hair pencil, set in tin, and fill it plentifully with the solution, and draw it slightly over the work intended to be fixed, once or twice, or according as the size of the picture may require: it must be very carefully done, to prevent disturbing the sharpness of the pencil-work. When dry it will be found to resist the effect of Indian-rubber. It is advantageous to sponge the back of the paper or Bristol-board before applying the solution, in order that the paper may dry level, as it

is apt to contract round the edges when only one side is wet. If there be a margin round the drawing it is not requisite to sponge the back. Milk and water answers the above purpose as well. So does alum water.

TO MAKE TRACING PAPER.

Dissolve one ounce of powdered clear white resin in two ounces of spirits of turpentine, then add thirty drops of the essence of lemons, shake it well for a few minutes. With a clean painter's tool varnish a sheet of tissue paper with the compound; hang it up to dry for thirty or forty minutes; then give the other side a coat with the same fluid. The tissue paper so prepared is beautifully transparent, and it will keep its appearance for years.

EASY METHOD OF TAKING A PERFECT COPY FROM A PRINT OR DRAWING.

Take a piece of clean lanthorn-horn; lay it upon the print or picture you wish to take off; then with a crow-quill dipped

in Indian ink, draw every stroke of the outline upon the horn; when dry, breathe upon that side of the horn whereon you have made your draft three or four times, and clap it directly on a damp piece of clean white paper, with the drawn side downwards; then, pressing it hard with the palm of your hand, the drawing will stick to your paper, and the horn come off clean.

This method is commonly practised by artists, and especially engravers, with a fine kind of hard and glassy paper, which is to be bought at an artist's colorman's in Oxford Street. The engravers scratch every line which is visible through the paper, and then rub red lead or red ochre over the whole; when reversed, it leaves the color on the ground laid on the copper-plate beneath, in the finest possible lines—ininitely finer indeed than the lines made by the pen, especially as these spread by the pressure used in transferring.

ANOTHER METHOD TO MAKE TRACING PAPER.

Mix together by a gentle heat, one ounce of Canada balsam, and a quarter of a pint of spirits of turpentine; wash over one side of the tissue paper. This dries quickly; is perfectly transparent, and is not greasy; therefore, does not stain the object upon which it may be placed.

BLACK LEAD PAPER.

Nothing more is necessary than to paint over with a brush a sheet of thin writing paper with black lead powder, mixed with water. When dry it will be fit for use. To use it, lay the black side on the paper you want the drawing transferred to; put the drawing on the paper, and trace it with something hard at the point.

NOTE.—Ink and water color, when to be used upon any kind of transparent oiled paper, must have a small quantity of gall mixed with them.

The Art of Drawing in Perspective.

PERSPECTIVE is the foundation of all the polite or liberal arts that have their basis in drawing; and indeed it is difficult to conceive how a person who has not either been instructed in, or been gifted by nature with some idea of the effects produced by locality and distance, can form anything like a correct opinion of the merits of those imitations of nature which come under the heads of portrait, landscape, figure, or architectural drawing.

Perspective is the art of representing, upon a plane surface, the appearance of objects, however diversified, similar to that they assume upon a glass pane interposed between them, and the eye at a given distance. The representation of a solid object on a plane surface can show the original in no other point of view but that from which it is at the time beheld

by the draughtsman ; the least change in any of the parts requires a change in the whole : nor can any deviation from the several lines, which will be hereafter explained, and on which the truth and correctness of the drawing depends be allowed, without changing the bearings, &c. of all the perspective lines.

Hence this art is absolutely necessary for such as would thoroughly understand that of drawing ; yet perspective of itself cannot be called a certain rule, but it is to be used with judgement and discretion ; for, being well understood, if it be applied too accurately the practitioner may indeed effect such things as are within the rules of art, yet the work will not always have that agreeable effect, that natural excellence and simplicity which a less rigorous observance of the rules of this art might produce ; therefore the young artist is to adhere to the precepts of perspective no further than as it leads to the perfection of his work or design.

EXPLANATION OF TERMS, ETC. IN
PERSPECTIVE.

Original Planes, or Lines, are the surfaces of the objects to be drawn; or they are any lines of those surfaces; or it means the surfaces on which these objects stand.

Perspective Plane is the picture itself, which is supposed to be a transparent plane, through which we view the objects represented thereon.

Ground Plane is the surface of the earth, or plane of the horizon, on which the picture is supposed to stand.

The Ground Line is that formed by the intersection of the picture in the ground plane.

The Horizontal Line is the vanishing point of the horizontal plane, and is produced in the same manner as any other vanishing line, viz. by passing a plane through the eye parallel to the horizontal plane.

Vanishing Points are the points which are marked down in the picture, by sup-

posing lines to be drawn from the spectator's eye parallel to any original lines, and produced until they touch the picture.

The Centre of a picture is that point on the perspective plane where a line drawn from the eye perpendicular to the picture would cut it ; consequently it is that part of the picture which is nearest to the eye of the spectator.

It would be useless to seek by the practical rules of perspective to describe all the little hollows and prominences of objects, or their smaller windings and turnings ; the infinite variety of the folds in drapery ; of the boughs and leaves of trees ; or the features and limbs of men and animals. For the rules designed to answer these purposes the reader is desired to consult the *Art of Drawing*.

It is true perspective is of most use where it is most wanted, and where a deviation from its rules would be most observable, as in pieces of architecture, &c. But with regard to such objects as have no certain determinate shape or size, such as clouds, hills, trees, rivers, &c. there is

a larger latitude allowed. But although the strict and practical rules of perspective are in a great measure confined to the description of right-lined figures, yet the knowledge of its general laws is of great and necessary use to inform the judgement in what manner the images of any proposed lines should run, and when terminate. It accustoms the eye to judge with greater certainty of the relations between real objects and their perspective descriptions, and directs the judgement more readily to discover any considerable error which might otherwise escape notice.

There are several mathematical instruments for the construction of geometrical diagrams, and for facilitating the drawing of perspective, which are valuable to professional men. The student, however, will acquire all the necessary information by attending carefully to the diagrams as they follow in these pages, with the few simple instruments described.

The Sector.

The following diagram (Fig. 1) repre-

sents a common sector; it is a semi-circle, or half circle; on the edge are marked twice 90, or 180 degrees; on the chord, or base line, is a point which determines the centre of the circle.

Fig. 1.

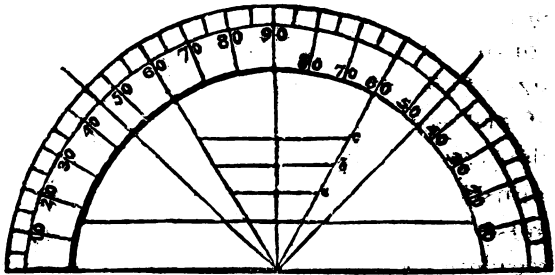

The attention of the student is particularly called to the use of this figure. The eye of a person when sketching from nature is supposed to be in the centre of a circle of 360 degrees, and the expanse of vision while the eye is stationary is an angle of 60 degrees, or 30 degrees on each side of the centre. This angle is found by drawing the diagonal lines from the centre on the chord to where 60 is marked on the edge of the sector to the right and

left. This angle of 60 degrees has no reference to the length of lines on either side, since they are regulated by the assumed width of the picture proposed to be drawn, as shown by the bases at *a*, *b*, *c*, on the expanse of 60 degrees. Each of these, being pictures, would represent the same scene, the objects of which it was composed being enlarged according to the size of the surface. This central situation of the eye which, with the extremities of the base line of the picture, under all circumstances, forms an equi-lateral triangle, must be particularly noticed, because it regulates the line by which a change in the situation of the eye or station is afterwards made. When any object, as, for instance, a house, presents its corner to the spectator both sides recede to their respective vanishing points on the horizontal line; and these points are found by drawing the diagonal lines from the station at an angle of 90 degrees, that is from the centre of the chord to where 45 degrees is marked on the edge of the sector, right and left of the perpendicular.

Fig. 2.

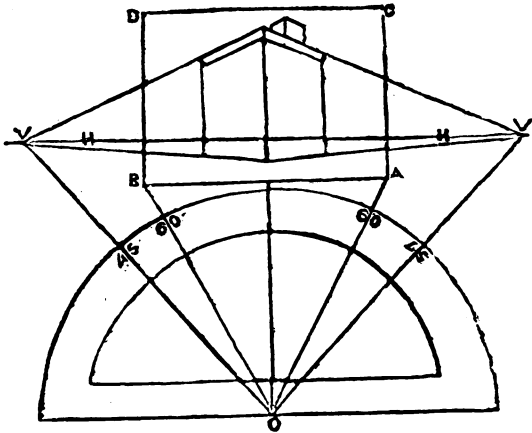

The above diagram (Fig. 2) represents the method of finding the vanishing points. Draw a, b , the base line, and also the boundary of the picture, c, d , and the horizontal line $h, h i$, find the half of the base, and draw a perpendicular to o , and on it place the profiled angle of 60 degrees, at that distance which, by continuing the sides of the angle, they will intersect the extremities of the base line and form an equi-lateral triangle. Then draw the diagonals from o through the

angle of 45 degrees, and where they intersect the horizontal line will be the vanishing points.

HORIZONTAL LINE AND POINT OF SIGHT.

Every person who has stood on the sea-shore may have observed the boundary line of the water meeting the sky. This may give the idea of what in perspective is called the *horizontal line*. That part of the horizontal line to which the eye of the spectator is directed is called the *point of sight*. The horizontal line and the point of sight may be fixed where they will best accord with the nature of the proposed picture. When looking on a straight road, which continues into the extreme distance, the edges of the road appear to terminate in a point.

This apparent diminishing of the road is determined by lines, or *visual rays*, being drawn from each side of the width of the road in front to the point of sight. The consideration of this may fix in the mind the fact, that all objects appear to dimi-

nish in proportion to their remoteness from the eye of the spectator. Hence, posts or columns of equal height will appear to become shorter as they recede from the eye, and the lines which regulate their diminutions or their visual rays must be drawn, as in Fig. 3, from the summit, and the base of the column nearest to the eye, to the point of sight, p , as in the following diagram.

Fig. 3.

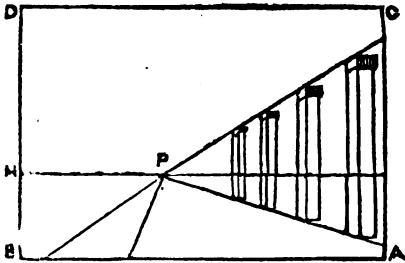

This is an illustration of objects of equal height seen in perspective; parts of which are above the horizontal line, while the road is an illustration of an object of equal width, seen in perspective below the horizontal line: a, b , is the

base on which the picture is formed ; *c, d*, the verticals, or sides of the picture, and with the line joining these at the top form the plane, or surface, on which the picture is represented. This surface may be regulated at pleasure : a proportion of a square and a half wide, by a square in height, is usually preferred. The horizontal line may be placed at pleasure, but it is generally regulated in its elevation by the nature of the subject to be drawn. If placed high, it leaves too small a proportion of sky, and produces what is called a bird's-eye view ; if placed low down, or too near the base, unless the scene be mountainous, it will appear insignificant, from having too great a proportion of sky. It is best to draw the horizontal line about one third the height of the picture. The point of sight may be fixed at pleasure ; it is generally better to place it a little from the centre of the picture.

TO DRAW A SQUARE BOX IN PERSPECTIVE.

Fig. 4.

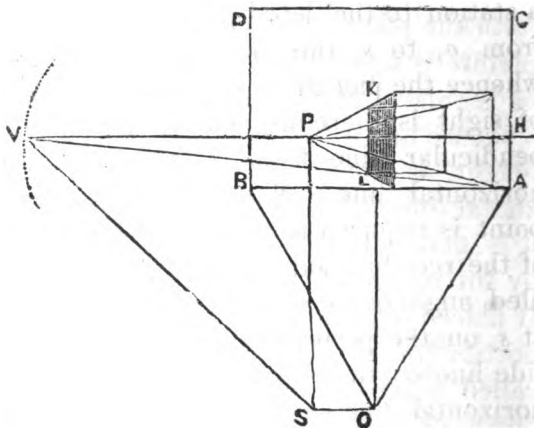

Apply the T square, and draw the base line *a, b*, and the boundary of the picture *c, d*. Then draw the horizontal line *h*; this may be fixed at pleasure. Then find the half of the base, *a, b*, and draw a perpendicular beneath the picture to *o*, and on it place the profiled angle of 60 degrees, just at that distance which, by continuing the sides of the angle, they will intersect the extremities of the base, and together from an equi-lateral triangle,

as a, o, b . Now, as before observed, the point of sight is better when removed from the centre of the picture; and taking a station to the left by a horizontal line from o , to s , this becomes the station whence the picture is seen, and the point of sight is therefore found by the perpendicular line from s , to p , on the horizontal line. Now, as a vanishing point is required to determine the width of the receding side of the box, the profiled angle of 90 degrees is to be placed at s , on the perpendicular, p, s , and the side line continued until it intersects the horizontal line at v , which fixes the vanishing point. It will be observed that the angle at s is one of 45 degrees; being the half of the profiled angle of 90.

The student's attention is called to the situation of the eye, which is always on a level with the horizontal line; therefore, the true position of s is immediately in front of p , or, as if the perspective lines beneath the picture could be raised up to the level with s , and fixed at that distance from the picture, to show the true

situation of the eye when viewing the object. The boundary of a picture, or the plane, may be of any proportions. The base in Fig. 4, is marked a, b . The perpendicular, from the middle of this base line, assists in finding the situation for the angle of 60 degrees, o ; the width of the base, measured from the extremities to the perpendicular, o , forming an equilateral triangle, as a, o, b . This is a rule, whatever may be the size of the picture: it also shows the proper distance at which a picture should be viewed. This expanse of vision, at an angle of 60 degrees, is marked in the diagram, o , and places the point of sight in the middle of the picture, which is very often objectionable: therefore, a line parallel with the base is drawn from o , and on this line the better station is taken, which is marked s . The horizontal line having been taken at pleasure, a perpendicular drawn into it from s , will give the point of sight at p , into which the visual rays are drawn that regulate the receding side of the object. The vanishing point, v , is entirely distinct

from the point of sight, of which there can be but one; but vanishing points may be numerous. That marked in the diagram, v , is of great consequence, for by it is determined the proper width of the object, by the line which intersects the visual ray from the base of the box, a , to v , as at l ; and here the perpendicular to k , which intersects the upper visual ray, completes the perspective form of the object.

Fig. 5.

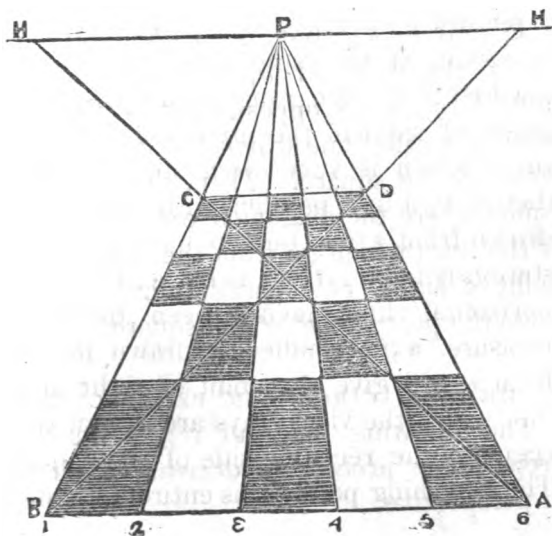

**TO DRAW A SQUARE PAVEMENT IN
PERSPECTIVE.**

Suppose a square pavement, consisting of twenty-five pieces, each a foot square. Having made an exact square of the size you intend your plan, draw your base line, a, b , and divide it into five equal parts. Then determine the horizontal line, h, h , and fix the point of sight, p , on the horizontal line; draw the visual rays from the base 1, 2, 3, 4, 5, 6, to the point of sight, p ; then rule diagonal lines from a, h , and b, h ; and, from the point c , where the diagonal a, h , intersects the lines, b, p , to the opposite intersection, d , draw a parallel line which is the abridgement of the square. Then, through the points where the diagonals cross the rest of the lines which go from the base to the point of sight, rule parallel lines, which gives the perspective of the square.

TO DRAW A CIRCLE IN PERSPECTIVE.

The following diagram represents the preparatory process of drawing a circle in perspective.

Fig. 6.

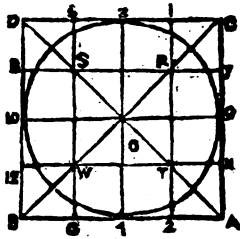

Describe a circle of any size with the compasses, and with the T square draw the boundary, so that the lines just touch the circle. Then draw the diagonals c , b , and d , a , and they will intersect the centre at o ; then divide the boundary lines, each into four equal parts, and draw the perpendiculars 1, 2, 3, 4, 5, 6; then the horizontals, 7, 8, 9, 10, 11, 12: If all have been truly done, these lines will intersect the diagonals, c , b , and d , a , as well as their own intersections, respectively at r , s , o , t , and w , as in the diagram Fig. 6.

Fig. 7.

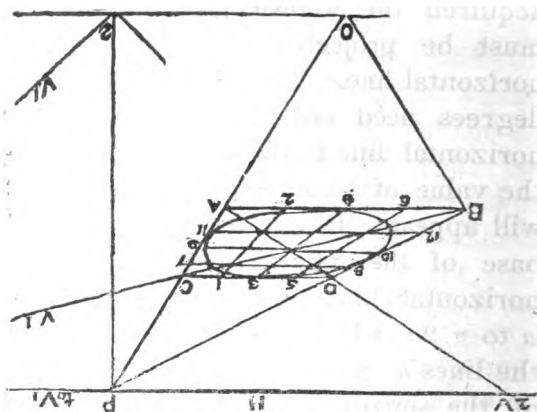

The base line, a , b , must be drawn and divided into four equal parts, as 2, 4, 6; then, from the base line, as in Fig. 4, determine the angle of 60 degrees, o . Let s be the station, and let the horizontal line be placed high up, as h , in order that the whole may be clearly seen; and, by the perpendicular, determine the point of sight p . Draw the rays, a , p , and b , p ; then, at s , take an angle of 90 degrees, and mark where at 45 degrees it would intersect the horizontal line on the right. This line is marked in the diagram to v 1,

because the student is presumed to have acquired the knowledge that this line must be projected till it intersect the horizontal line. The other angle of 45 degrees need only be marked on the horizontal line to the left, as *v 2*. Now the value of these two vanishing points will appear. Draw the diagonal from the base of the square, *b*, to *v 1*, on the horizontal line, and the diagonal from *a* to *v 2*; where these have intersected the lines *a, p*, and *b, p*, the perspective of the square, *a, b, c, d*, is determined; then draw the line, *c, d*, from the base line, 2, 4, 6, draw lines to the point of sight *p*, which lines give the diminutions, 1, 3, 5, and where the lines intersect the diagonals, *a, b*, draw horizontal lines from 7, 8, 9, 10, 11, 12; this square in perspective is the basis on which the circle is to be drawn.

The student must observe through what points and diagonals the outline of the circle passes in Fig. 6, and slightly mark with the pencil on Fig. 7, a corresponding outline; this will require a little

care not to confuse the lines. It will be better to put the perspective square in ink, and the remainder in finer lines, that the sketching may be corrected where wrong, until agreeing with the circle in Fig. 6, through all the diminishing parts of the square; after which it may be carefully drawn in with a pen and ink stronger than any of the other lines.

Circles may be put into perspective, when seen at any angle, by previously constructing their corresponding squares. When seen in front the point of sight is in the middle on the horizontal line, and when seen from any removal to the right or left the equi-lateral triangle of 60 degrees gives the point for the parallel line to the station, far or near, and there the angle of 90 degrees will give the vanishing points by projecting the respective sides to the horizontal line; the diagonals from the basis of the square to the opposite vanishing points will give the abridgment, and the rest will be found by the process as Fig. 7.

THE PROCESS OF DRAWING A DOUBLE
CROSS IN PERSPECTIVE.

Fig. 8.

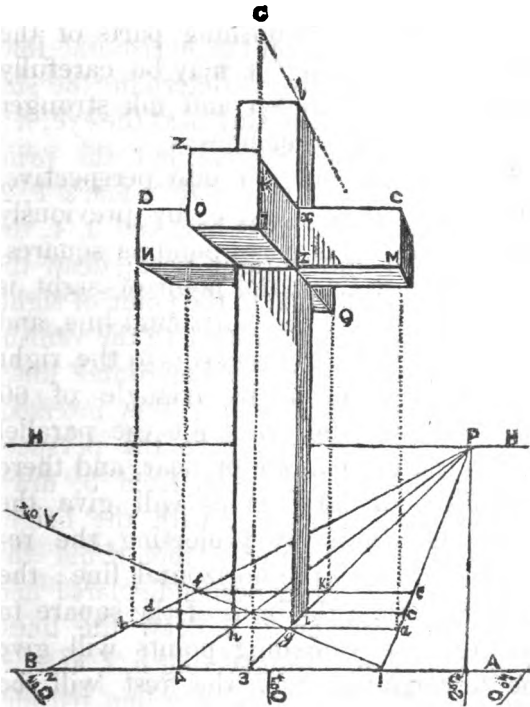

Draw the base of the picture, *a*, *b*,
(Fig. 8.); take the angle of 60 degrees,

as before, at o , and the station at s ; draw the horizontal line h, h ; draw the perpendicular at s , and the point of sight will then be at p ; then take an angle of 90 degrees at s , and the vanishing point will be at v , on the horizontal line. The student will always determine the size of the object on the side next the eye, it is assumed, in the diagram, but the principles apply to all sizes; then mark 1, 2, the extent of the cross-bar, and 3, 4, the thickness of the upright post; draw the visual rays, 1, 3, 4, 2, to the point of sight, p , and the diagonal from 1 to the vanishing point, v ; draw the horizontal lines, a, b, c, d, e, f , and where they intersect the diagonal line will give the perspective of the upright post, from 3, draw the perpendicular to g , with the height of the parts required; then from the points, g, h, i , draw perpendiculars; and from the points on 3, g , draw the lines, g, p, k, p, i, p . Intersecting g, l , at x, z , draw through the point, z , a line parallel to the base line from m, n , and another parallel to it from c, d ; describe per-

pendiculars from *b*, *d*, *4*, *z*, *k*, *q*, and *a*, *c*; then draw the lines, *o*, *p*, *n*, *p*, *m*, *p*, and *c*, *p*, which will give the perspective of the cross.

When the student has proceeded thus far, he may commence sketching from different objects, such as articles of furniture, a tree, the leaf of a plant, or any thing that may strike his fancy. In delineating objects correctly the pupil will at every step find occasion to revert to the principles of perspective, and see the necessity of strictly adhering to them.

The student must consider that objects when differently situated have each their vanishing points, regulated by the angle at which they are viewed; on all occasions draw the horizontal line so far on either side as to be intersected by the diagonals, which are to be drawn at an angle of 90 degrees from the station into the horizontal line, where they determine the vanishing points. These are only indicated in the diagrams by the direction of those lines and the word to "v 1, or v 2." Let it be observed,

that a vanishing point is required for each variety of surface that may be presented to the eye.

After the early rules of perspective have been learned, the student may commence with a few lessons of sketching from nature. The scene selected should not contain more than three or four objects of different kinds. As an example of the scenes which may be selected for early sketches, Fig. 9 is given.

Fig. 9.

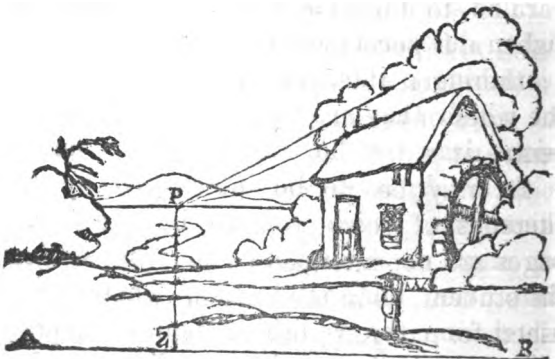

The station of the draughtsman is here at *s*, in order that the cottage may not appear

to have been viewed formally, and that the trees behind may give to the scene its neat pyramidal form, while the broken ground in front gives boldness of character. P is the horizontal line and point of sight: a few lines expressive of the leading features of a scene become more valuable than if a multitude of markings were introduced; all these attempts to *make out* should be avoided for the present. The perspective lines to the sketch may be proved at any convenient opportunity. In Fig. 9. the cottage stands in a line parallel to the base, a, b . The point of sight, p , is perpendicular to the station of s ; therefore, the rays which regulate the the sides of the chimney and the roof, all centre at p .

It may be proper to mention that sketches of scenery presented in these pages are not intended to be imitated by the student, as in the case of prints published for copying, but are given simply with the view of illustrating the lessons we are attempting to convey.

Supposing a scene to consist of two or

more plans, as the ruins of a castle, &c. with a mass of trees in front, &c. it is recommended, should there be any similar union of objects in the neighbourhood, for the student to visit the spot, that the hints which accompany the following diagram may be examined, and the principles on which the proceedings are founded, may be investigated.

Fig. 10.

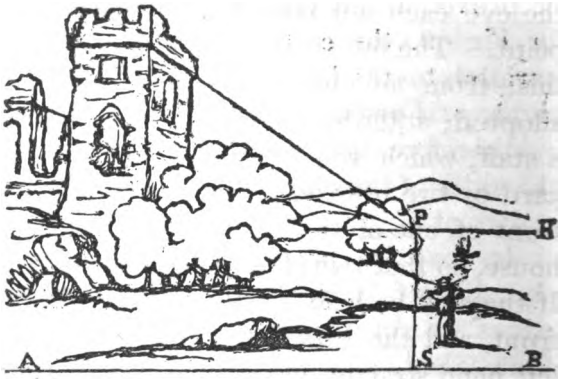

The castle, toward one side of the picture, and the distance on the other, forms an irregular diagonal mass, and are in better relief than if the buildings with

the trees were more in the middle of the subject. Proceed to arrange the situation of the principal mass, by dotting on the edge of the sketch-book. Determine the horizontal line, observing that hills may appear, far above ; in Fig. 10, it is at h ; the station is at s , and, consequently, the point of sight is at p , into which are drawn visual rays, which regulate the receding sides of the tower. It will have been seen that when any object presents two sides to the eye each side must have its vanishing point. The following method of proving this, from an object in nature, may be adopted ; at the height of the eye attach to a staff, which you hold in your hand, a yard or two of thread ; select a station in front of one of the angles of a detached house, so that two of its sides are visible. If the staff be held a little to the right in front, and the thread extended with the left hand straight across, it will represent the horizontal line, and the point of sight will be on it, immediately facing the person making the observation. By raising this thread with the left hand while the

eye is kept stationary, and at the same time moving the staff nearer or more distant, sidewise, till the inclination of the thread is in agreement with the inclination of the tops of the roof, windows, and door on one side of the house. The termination of the line so formed will be where the thread is attached to the staff. This termination is the vanishing point. The architectural regularities on the other side of the house must then be traced in a similar manner to their vanishing point on the horizontal line. Let all this be done deliberately, and it will show that whatever may be the difference in the dipping of the thread, on the respective sides of the house to their vanishing points, they will be comprehended in an angle of 90 degrees, taken at the station ; on such occasion the point of sight is in the object viewed, and, perhaps, in the centre of the picture ; in which case its base, or width, regulates the station, and the vanishing points are on each side of the point of sight at the same distance as the station. This may be exemplified in

the different diagrams by placing one foot of the compasses at p , and extending the other to s , when by sweeping an arc from s , it will intersect $v, 1$, and $v, 2$, on the horizontal line. It will be here proper to repeat that in the diagrams, such, for instance, as Fig. 10, the s is placed for convenience higher up than it ought to be; its real position being at the lower point of the equi-lateral triangle; on which all sketches are constructed.

In selecting scenes from nature, the expanse of vision, or 60 degrees, will often include more of the scenery surrounding an object than is required: on such occasions the boundary lines may be placed at pleasure, or so as to give the best effect to the principal; a foreground must ever be more or less imaginary, because the space between the objects which compose the scene and the spectator cannot be otherwise filled up. The situation in which a drawing is seen to the greatest advantage is when its horizontal line is immediately in front of the spectator's eye, and at such a distance that the whole

can be seen without requiring the head to be moved.

ÆRIAL PERSPECTIVE.

Ærial perspective is the art of giving a proper diminution, or degradation, to the strength of the light, shade, and colors of objects, according to their different distances; the quantity of light which falls on them, and the medium through which they are seen.

As the eye does not judge of the distance of objects entirely by their apparent size, but also by their strength of colors, and distinction of parts, so it is not sufficient to give an object its due apparent bulk according to the rules of perspective, unless at the same time it be expressed with that proper faintness and degradation of colors which the distance requires

NOTE.—Instructions for coloring, &c., will be given in the “Art of Painting in Water Colors.”

Recípes, &c.

TO COLOR UNSIZED PRINTS.

Those who colour engravings, which have been printed on unsized or bibulous paper, make use of the following composition, which is very similar to that employed in the paper manufactories. Four ounces of Flanders glue and four ounces of white soap are to be dissolved in three pints of hot water. When the solution is complete, two ounces of pounded alum must be added, and as soon as these ingredients are well mixed the composition is fit for use. It is applied cold with a sponge, or rather with a flat camel-hair brush.

PAPIER MACHEE

consists of cuttings of white or brown paper, boiled in water, and beaten in a mortar till they become a kind of paste, and mixed with a solution of gum arabic in size, to give tenacity to them. The

pulpy mass thus formed is made into tea-boards, toys, &c., by pressing it into oiled moulds. When dried it is covered with a mixture of size and lamp black, and afterwards varnished. It is from this material that the scrolls, wreaths, and rosette ornaments for theatres, decorative cornices, &c., are frequently made, being gilt afterwards. Also, the French, who excel in papier machee work, are accustomed to make numerous models, painting them with fresco colors—that is, with various pigments mixed with whiting, or some opaque color. Of this description have been formed models of the chief routes through Switzerland, in which the foundation, or general surface, is of paper, formed irregularly, and colored to resemble mountains, &c. The glaciers are of coarsely pounded glass—the roads painted brown—the rivers blue—the woods made of the pile of velvet cut off, and the villages of cork.

The Art of Miniature Painting.

MINIATURE painting is practised either on vellum or ivory. The latter is the material most generally used at present for painting in miniature, and we shall proceed to give the best and most approved method for painting on ivory. The first essential point in this, as in all other branches of painting, is a thorough and well grounded knowledge of drawing. No one can hope to excel without correctness of drawing, as the greatest brilliancy of tints without it will at last be unsatisfactory.

Painting in miniature is the most delicate and tedious in its process of any painting, being wholly performed with the point of the pencil. It is only fit for small works, and must be viewed near.

COLOURS USED IN MINIATURE PAINTING.

In painting the face, the yellows used

H

are gall-stone, terra sienna, yellow ochre, and gamboge; Prussian blue, smalt ultramarine, carmine, lake, vermilion, Indian red, and burnt umber. For painting draperies we shall only add to the above colours, ivory black, King's yellow, chrome, and flake white.

Gum Water.—Choose the largest white pieces of gum arabic; put them in a clean phial and pour water on them; it must be as thick as you can feel it in your fingers; the fresher it is made the better.

Hair Pencils.—The pencils are of two kinds, camel-hair and sable; the latter are of a stiffer nature than the camel's hair, and are a useful kind of pencil as long as the fine flue at the end of the hair remain, on account of their elasticity; when that is worn off they become, from their harshness, useless. As the delicacy of this work depends much on the goodness of the pencils, great care is requisite in selecting them.

The error too prevalent with young miniature painters is that of choosing a very small pencil for their work, thinking

to execute their picture with more neatness and accuracy; in this they will find themselves by experience to be mistaken, the finest and most highly finished picture being executed with a middling sized pencil. In order to make a good choice, the young artist should wet the pencil a little, and if the hairs keep close together when pressed on the thumb-nail the pencil is good; if he finds it on being moderately wet to spring again into form after being bent it is a good sign; but as there are many pencils possessed of that quality which are deficient of another, that is, a good point, they must be very cautiously looked to, by turning the pencil round on the nail in every direction, observing the hairs at the point keep equally together, of a length, and none spreading out on either side, if they do, the pencil is useless.

IVORY.

Method of Choosing and Preparing it.

There are various kinds of ivory; the distinction of which in this art is of very

material consequence. Ivory, newly cut and full of sap, is not easily to be judged of, unless to the artist who by a long course of experience is familiarized to it. The best way to discover the quality of it is by holding it grainways to the light, then holding it up and looking through it, turning it from side to side, and very narrowly observing if there are any streaks in it; this you will, unless the ivory is very freshly cut, easily discover, and in this you cannot be too particular.

There is a species of ivory which is very bad for painting on although it has no streaks in it, being of a horny, coarse nature, which will never allow the colours to be thrown out in the brilliant manner a fine species of ivory will. You must therefore not only be cautious in choosing ivory free from streaks, but likewise that which has the finest grain, and close. We shall now proceed to treat on the manner of preparing the ivory for painting on.

Ivory may be purchased ready prepared for painting on, but as it is not always convenient to procure it the following di-

rections are given. You must first fasten the ivory, with some thick gum round the edges, to a piece of pretty stout drawing paper, and place a weight on it till dry; then scrape it with a razor, sharpened to a roundish edge, until all the scratches of the cutting-saw are obliterated. You are then to rub two pieces of pumice stone together until the dust covers the ivory leaf, after which rub it well with a piece of writing paper in a circular manner, and when by holding it up against the light you find every part has received the pumice, and all the scratches have disappeared, the ivory is then fit for painting on.

OF COMPOUND TINTS FOR THE FACE.

Grey.—Of grey tints there are various kinds. A warm grey tint may be made with burnt terra sienna, Prussian blue, and lake; another of Prussian blue and Indian red; and a third is formed of lake, sap green, and Prussian blue.

Olive Tints.—A very fine olive tint is

formed of gall-stone, Nottingham ochre, and carmine, or lake, and another of sap green and lake.

Hair Tints.—A beautiful hair colour, either dark or light, according to the quantities of colours, is made of carmine, ivory black, and sap green. The manner of forming it is only to be acquired by practice. That very difficult tint which is often met with in childrens' hair, by the proper junction of these colours, will be produced to perfection. Some excellent painters make all their hair tints of burnt terra sienna, ivory black, and Nottingham ochre, the latter being added only when there is light hair to be represented.

OF PAINTING DRAPERIES.

It is necessary in painting cloth draperies for mens' portraits to add flake white, as it not only gives the colour the dead appearance which cloth has, but likewise gives it a body, which makes the flesh tints appear to more advantage. In mixing the colours for your draperies you must make them

appear several shades lighter than you want them, as the flake white being so very heavy sinks to the bottom, and leaves your colour much darker than when it was wet.

Black drapery is made of ivory black and flake white, and must be laid in with a good quantity of the latter or it will be difficult to manage the shadows so as to produce a pleasing effect.

Blue may be formed either with Prussian blue, or Antwerp blue, mixed with flake white.

Green, of King's yellow, or chrome, mixed with Prussian blue.

Yellow drapery is best painted with King's yellow laid thin.

Drab colour is made with raw umber and white.

Claret colour, terra de Cassel, a little ivory black, and lake.

Lilac is formed of carmine, Prussian blue, and white.

Grey, by a mixture of ivory black, flake white, and a small portion of lake.

Scarlet, is a colour very difficult to lay

down rules for making, as in some pictures it is dangerous to make it too bright, for fear of hurting the effect of the face. If the subject you are painting from life is very pale, you run a great risk, by annexing a very bright scarlet to the picture. A very bright scarlet is made of vermilion and carmine, without flake white; and if you want it still brighter, when it is dry fill your pencil with carmine, mixed with gum water, and glaze over it carefully; if you wish to render it less brilliant add a little flake white to it.

PAINTING THE FACE IN MINIATURE.

The palette used in miniature painting is made of ivory, on which the colours are generally arranged as follows, beginning on the left hand:—Indian red, burnt terra sienna, yellow ochre, gamboge, carmine, vermilion, light red, burnt umber, ivory black, and Prussian blue; in finishing, gall-stone may be added.

To fasten the ivory put a little thick gum water at the back, and lay it on a piece of paper, doubled over so that it

will fold over your ivory; you can then pin it to a book, or anything convenient, placed in a sloping direction. Some artists use a mahogany desk, about fourteen inches high, and a foot-board at the top; there is to be a lid, covered with green baize, which must have a pair of small hinges at the front, and to lift occasionally, with a supporting rail at the back, and notches, to readily adjust it to any height. About the middle of the green baize there is to be a slip of very thin mahogany, glued at each end, but the centre of it left free, to fasten your ivory by slipping it between the mahogany and green baize.

The light is of great importance in this kind of painting, and must be particularly attended to, it not being like oil painting, where the rays of the sun may be kept out by blinds, &c., without causing any material inconvenience. A north light, or as near it as possible, is the best. It ought to enter the room by one window only, and if there is more than one, the other ought to be closed; the one you

sit by is to have a green baize curtain against the lower part of it, to reach about a foot higher than your head as you sit at your painting desk, with your left hand towards the light.

Having placed your sitter at the distance of about a yard and a half from you, begin by drawing the outlines of the face very carefully, with a moderate size pencil, and a light neutral tint, made of Prussian blue and Indian red. When you have drawn them correctly, begin to lay the colour in faintly of the eye, the shadows under the eyebrows in a grey tint, and under the nose in broad faint washes; and you must also particularly observe in the process of painting a miniature, to go on faintly at the beginning: if you attempt to hurry it, your colours to a certainty will look dirty, and your picture harsh and disagreeable. Having laid in your grey tints where your shadows are to fall, go on heightening them by degrees, with a middling full pencil, not too washey or too dry. When you have pretty strongly marked them out, go over

the different parts of the face, where the shadows do not come, with a light wash of gall-stone, or Indian red, and yellow ochre ; and then proceed to heighten the colours on the cheeks, the beard, &c., working with fine strokes in various directions ; so that after some time working it will appear like so many fine dots, or points, observing as a general rule that it is much easier to warm the tints of the face than to cool them. It is therefore best to begin with cool greys and purple, and towards the finishing of the picture to add warmth, by gradually working such colours as gall-stone, burnt terra sienna, &c., in addition to the carmine or lake that may be necessary to produce the tint of nature. If your colours should get too thick, or any dust, you must use a pen-knife, ground to a nice round point, with which you can remove anything you may require. It is necessary to be very careful in the use of it not to press too hard, or you will get down to the ivory. After a little practice you will find it a very useful article, as it is almost impossi-

ble, without a great degree of labour, to produce a fine finished miniature without it.

From the variety of style adopted by different miniature painters, it is very difficult for a young beginner to judge which is best to follow, and as there is a certain degree of mechanical attention to be paid to the management of the water colours, to preserve them clean and free from muddiness, which is difficult to attain, -we recommend to the young artist to procure a good miniature, and observe the style of pencilling, and the management of the colour; at the same time letting nature be his guide in the colouring of his picture. In painting the back ground, which you must do gradually, with the face, begin by washing in the colour with a pencil, moderately filled, in broad faint strokes. You must then proceed with little light strokes, crossing one another in all directions, and filling in when the colour appears faint until the work at last has the appearance of being done with dots.

The colours are to be ground with gum water, a little weak, and used during the progress of the painting. In painting a head on an oval piece of ivory draw the chin as nearly as possible in the centre of the ivory.

Marking consists in the sharp spirited touches given to the different features in order to give that animated appearance so necessary to constitute a fine picture.

Crayon Painting.

WHETHER the painter works with oil colours, water colours, or crayon, the grand object of his pursuit is still the same, a just imitation of nature. Each species has its peculiar rules and methods. Painting with crayons, requires, in many respects, a treatment different from painting in oil colours, because all colours used dry are in their nature of a much warmer hue than when wet with oils or any other binding fluid. In order to produce a rich picture, a much greater proportion of cooling tints must be used than are requisite with oil. We shall now

endeavour to give the student some directions towards the attainment of excellence in this art.

Having procured some crayon paper, it must be pasted very smooth on a linen cloth, previously strained on a deal frame. On this the picture is to be executed; but it is better not to paste the paper on till the whole subject is first dead coloured. The advantages arising from pasting the paper on the frame after the picture is begun are very great, as the crayons will adhere much better than in any other way. The student will find the sitting posture, with the box of crayons on his lap, the most convenient method for him to paint. The part of the picture he is painting should be rather below his face, for if it is placed too high, his arm will be fatigued. The windows of the room where he paints should be darkened, at least six feet from the ground, that the light may fall with every advantage on the face, avoiding too much shadow, which seldom has a good effect in portrait painting, particularly if the face he is painting has any degree of

delicacy. The features of the face being carefully drawn with chalk, take a crayon of carmine, and carefully draw the nostril and edge of the nose, and next, the shadow; then, with the faintest carmine tint, lay in the strongest light upon the nose and forehead; you must then proceed gradually with the second tint, and the succeeding ones, till you arrive at the shadows, which must be covered brilliantly, enriched with lake and carmine, a little broken with green; this method will at first offensively strike the eye, from its crude appearance, but in finishing it will be a good ground to produce a pleasing effect. The several pearly tints discernable in fine complexions must be imitated with blue verditer and white, but if the parts of the face where these tints appear are in shadow, the crayons composed of black and white must be substituted in their place. When the student begins to draw the eyes, use a crayon inclined to the carmine tint; let the light of the eye incline to the blue cast, cautiously avoiding a staring white appearance, preserving

a broad shadow, thrown on its upper part by the eyelash. A black and heavy tint is also to be avoided in the eyebrows, which should be executed like a broad glowing shadow at first, on which, in the finishing, the hairs of the brow are to be painted. The lips should be begun with pure carmine and lake; the strong vermilion tints should be laid on afterwards. If the hair is dark, he should preserve much of the lake and deep carmine tints: this may be easily overpowered by the warmer hair tints, which, as in painting the eyebrows, will produce a richer effect when the picture is finished. When the head is brought to some degree of forwardness let the back ground be laid in, which must be treated in a different manner, covering it as thin as possible, and rubbing it into the paper with a leather stump. The ground being painted thin next the hair, will give the student an opportunity of painting the edges of the hair over in a light and free manner, when he gives the finishing touches. The student should view the whole at some

distance, being particularly attentive to the white or chalky appearances, which must be subdued with lake or carmine. The next step is to complete the back ground and hair, as the dust falling on the face would much injure it, if that was completed first; from thence proceed to the forehead, finishing downward till the whole picture is completed. It must be remembered the light must always be placed against the dark, and the weak against the strong, in order to produce force and effect, and *vice versa*.

In painting over the forehead the last time, begin the highest light with a faint vermilion tint in the same place where the faint carmine was first laid. In the next shade, succeeding the lightest, the student must work in some light blue tints of verditer and white, intermixing with them some of the deeper vermilion tints, and sweetening and melting them into each other with great care. Beneath the eyes the pearly tints are to be preserved, composed of verditer and white, and under the

nose, and on the temples, the same may be used.

The introduction of greens and blues into the face has often surprised those unacquainted with the art, but the reason for doing so is to break and correct the other colours. In finishing the cheeks let the pure lake clear them from any dust; then the lake may be intermixed with vermilion, and, should the subject require it, a few touches of the orange-coloured crayons; but this must be used with caution; after this, sweeten that part with a stump as little as possible.

The eye is the most difficult feature to execute in crayons. To accomplish this part will be a good general rule for the student to use his crayon in sweetening as much, and his finger, or stump, as little as possible. When he wants a point to touch a small part with he may break off a little of his crayon against his box, which will produce a corner fit to work with in the minutest parts.

The difficulty with the nose is to pre-

serve the lines properly determined, and at the same time so blended into the cheek as to express its projection, and yet no real line to be perceptible upon a close examination. The shadow caused by the nose is generally the darkest in the whole face, partaking of no reflection from its surrounding parts. Carmine and brown ochre, or carmine and black, will compose it best. Having before prepared the lips with lake and carmine, you must with these colours make them completely correct, and when finishing introduce the strong vermillions, but with great caution. In colouring the neck let the student preserve the stem of a pearly hue, and the light not so strong as on the chest.

The perfection of the crayons consists, in a great measure, in their softness, for it is impossible to execute a brilliant picture with them if they are otherwise. The usual objection to crayon painting is, that they are subject to changes. The following method of fixing the colours will be found very useful. In order to succeed in this ope-

ration the picture should be placed vertically, or rather a little inclined from the perpendicular upon the easel, or a chair to keep it steady. A brush should be provided, with the hairs of a middling length, and a small iron rod, six or seven inches long, of a triangular form, bent at one end ; then take a pint of the clearest water, into which put two large pieces of the best isinglass, cut small ; when dissolved strain the liquor through a piece of fine linen. When this is used it is poured into a saucer and mixed with twice its quantity of the best spirits of wine : while the mixture is about milk warm, dip the brush in it, and pass it several times over the bent end of the small iron rod, drawing it towards you so as to press the hairs together ; this forces the greatest part of the liquor to fall off, and leaves the hairs only moistened ; then holding the hairs of the brush towards the picture, at a distance of eight or ten inches, apply to the hairs the bent end of the rod, and drawing it towards you, the several hairs as they escape and return

to their original position will throw off the moisture adhering to them, and thus produce on the picture a sort of imperceptible shower which will penetrate the crayons and fix them. When the brush is dry it is again dipped in the saucer, and the operation is continued, beginning at one corner until the whole surface has been done over. When the whole has been moistened, let it dry, and then repeat the operation twice or more, if you think it has not been sufficiently done at first.

The crayons should be arranged in classes, for the convenience of painting with them; and when the student is desirous of making a drawing, either from nature or otherwise, he should ascertain before he begins that he has every colour which he may require, as he cannot here, as in painting either in water or oil colours, prepare a colour at a minutes notice. In order to keep the colours separate (for if they mix it will, on account of their softness, be very prejudicial to them), you should be provided with a box with thin

drawers, divided into a number of partitions. The crayons should be placed according to the several gradations of lights, the bottom of the partitions should be covered with bran, or wool, as a bed for the colours, because it not only preserves them clean but prevents them breaking. The box made use of when the student is painting should be about a foot square, with nine partitions. In the upper corner, on the left hand, (supposing the box to be in his lap) let him place the black and grey crayons (those being the least used); in the second partition the blues; in the third the greens and brown; in the first partition, on the left hand of the second row, the carmines, lakes, vermillions, and all deep reds; the yellows and orange in the middle, and the pearly tints next; and these last, being of a very delicate nature, must be kept clean, that the gradations of colour may be easily distinguished: in the lowest row have a fine piece of linen rag to wipe the crayons while they are using. The second, all the pure lake and vermilion tints; and

the other partitions may contain those tints which, from their complex nature, cannot be classed with any of the former.

Grecian or Persian Painting.

THIS description of painting is very easy of attainment, and requires but a very slight knowledge of drawing. If the following instructions are carefully attended to they will most likely be found all that is requisite to succeed in this style of drawing. It is executed on a particular kind of paper, called Grecian paper, covered with a chalky substance, resembling that on visiting cards, with the surface rather rough, and of a yellowish white colour, and has a peculiar scent, something like oil-cloth. Powder colours are used, which are mixed together dry, and rubbed on in the same state with the finger, taking no heed of doors, windows, &c., which are scraped out afterwards with a pen-knife. This style of colouring, when finished, looks very like a well and

softly executed chalk drawing, and is very appropriate for landscapes, particularly ruins.

The materials necessary are as follows:—Grecian paper, and the following colours in powder :—constant white, ivory black, vandyke brown, Italian pink, yellow ochre, chrome yellow, Indian yellow, mazarine blue, cobalt blue, crimson lake, Indian red, and vermillion.

The following chalks (Conte's) :—Two shades of light green, one bright yellow, one yellowish white stone colour, one grey, one light brown, and one hard, and one soft black.

Make a varnish to set the drawing, of picked mastic, two grains, and spirits of wine one ounce.

A little sepia in lump, and the following:—a brush, such as is used for a small-tooth comb, a pen-knife, a camel's hair pencil, a stumper, and three or four little cups or jars to mix the colours in. Prints will do for copies done on a larger scale in the painting, and the colouring must be according to subsequent direction.

The outline of the buildings and trees are to be sketched with the hard black Conte, taking no notice of doors, windows, or other minutiae: then mix your colours.

Sky.—Cobalt blue and white, sometimes a little black for the clouds, but sparingly.

Buildings.—Yellow ochre and white, or vandyke brown and white, shaded with black.

Roofs and Chimneys.—Vermillion, shaded with Indian red, or black.

Trees.—Mazarine blue, black, and Indian yellow; they should be painted dark, as the foliage (which is done with the green Contes) renders them lighter. The stems should be done with the brown Contes, and shaded with the soft black one.

Ground.—Vandyke brown and white, shaded with neutral tint; which is made with Indian red and very little mazarine blue; Italian pink may be used for sandy ground, as also green for that covered with herbage.

Water.—Mazarine blue and white,

shaded with black. Foam and the high lights are produced by scraping off the colours with a knife.

The lighter parts are all produced by adding a little white. After the colours are rubbed in with the fingers, the drawing is to be occasionally outlined with the black Conte; the lights are then to be removed with the knife (doors, windows, &c., the same way). The varnish is then to be laid on by putting a few drops on the brush, and splashing the drawing all over by drawing the finger on the hairs of the brush. It may then be touched up with a little sepia or other water colour, as the subject may require; but the water colour is not necessary, as the proper effect can generally be produced by using the coloured Contes'. The crimson lake is used for drapery, warm tints in the sky, &c. The stumper for working off the colour when laid on too dark.

Recipes, &c.

Bleaching Ivory.—Ivory is very apt to take a yellow brown tint by exposure to the air. It may be whitened or bleached by rubbing it first with pounded pumice stone and water, then placing it moist under a glass shade, and exposing it to sunshine. The sunbeams, without the shade, would be likely to occasion fissures in the ivory. The moist rubbing and exposure may be repeated several times.

To make Black Chalk.—Chalk or charcoal is first to be sawed in three-inch lengths, free from knots; then saw them, longitudinally, in narrow strips. Procure a tin trough, about four inches by three, and partly fill it with white wax, and after properly melted, the pieces of charcoal are to be saturated for forty-eight hours, and after draining they are fit for use.

Coloured Crayons, Are made of the following composition:—six parts of shel-

lac, four parts of spirits of wine, two parts of turpentine, twelve parts of a colouring powder, such as Prussian blue, orpiment, white lead, vermilion, &c., and twelve parts of blue clay. The clay being elutriated, passed through a hair sieve, and dried, is to be well incorporated by trituration with the solution of shell-lac in the spirit of wine, the turpentine and the pigment; and the doughy mass pressed into moulds. They are to be dried by a stove heat.

Ivory Paper.—The properties which render ivory so desirable a subject for the miniature painter and other artists, are the evenness and fineness of its grain, its allowing all water colours laid on its surface to be washed out with a soft wet brush, and the facility with which the artist may scrape off the colour from any particular part by means of the point of a knife, or other convenient instrument, and thus heighten and add brilliancy to the lights in his painting more expeditiously and efficaciously than can be done in any other way.

The objections to ivory are, its high price, the impossibility of obtaining leaves exceeding very moderate dimensions, and the coarseness of grain in the largest of these, its liability when thin to warp by changes of the weather, and its property of turning yellow by long exposure to the light, owing to the oil which it contains.

Traces made on the surface of this paper by a hard black lead pencil, are much easier effaced by the Indian-rubber than from common drawing paper, which circumstance, together with the extremely fine lines which its hard and even surface is capable of receiving, peculiarly adapts it for the reception of the most delicate kind of pencil drawing and outlines. The colours laid upon it have a greater brilliancy than when laid upon ivory, owing to the superior whiteness of the ground. The following is the process given by Mr. Einslie, (of Stretton Ground, Westminster) to the Society of Arts, for which he was voted the sum of thirty guineas.

“Take a quarter of a pound of clean

parchment-cuttings, and put them into a two-quart pan, with nearly as much water as it will hold; boil the mixture gently for four or five hours, adding water from time to time to supply the place of that driven off by evaporation; then carefully strain the liquor from the dregs through a cloth, and when cold it will form a strong jelly, which may be called size (No. 1).

“ Return the dregs of the preceding process into the pan, fill it with water, and again boil it as before for four or five hours; then strain off the liquor, and call it size (No 2).

“ Take three sheets of drawing paper (outsides will answer the purpose perfectly well, and being much cheaper are therefore to be preferred), wet them on both sides with a soft sponge dipped in water, and paste them together with the size (No. 2); while they are still wet, lay them on a table and place them upon a smooth slab of writing slate, of a size somewhat smaller than the paper, turn up the edges of the paper and paste them

on the back of the slate, and then allow the paper to dry gradually. Wet as before three more sheets of the same kind of paper, and paste them on the others, one at a time; cut off with a knife what projects beyond the edges of the slate, and when the whole has become perfectly dry, wrap a small piece of slate in coarse sand-paper, and with this rubber make the surface of the paper quite even and smooth. Then paste on an inside sheet, which must be quite free from spots, or dirt of any kind; cut off the projecting edges as before, and, when dry, rub it with fine glass paper, which will produce a perfectly smooth surface.

Now take half a pint of the size (No. 1), melt it with a gentle heat, and then stir into it three table spoonsful of fine plaster of Paris; when the mixture is completed pour it out on the paper, and with a soft, wet sponge distribute it as evenly as possible over the surface. Then allow the surface to dry slowly, and rub it again with fine glass paper. Lastly, take a few spoonsful of the size,

(No. 1), and mix it with three-fourths its quantity of water ; unite the two by a gentle heat, and when the mass has cooled, so as to be in a semi-gelatinous state, pour one-third of it on the surface of the paper, and spread it evenly with the sponge ; when this has dried pour on another portion, and afterwards the remainder ; when the whole has again become dry, rub it over lightly with fine glass paper, and the process is completed. It may accordingly be cut away from the slab of slate, and is ready for use.

The quantity of ingredients above-mentioned is sufficient for a piece of paper $17\frac{1}{2}$ by $15\frac{1}{2}$ inches.

Plaster of Paris gives a perfectly white surface ; oxide of zinc, mixed with plaster of Paris in the proportion of four parts of the former to three of the latter, gives a tint very nearly resembling ivory.

The Art of Engraving on Wood.

THE early history of wood engraving is involved in considerable obscurity. Various arguments have been brought forward to support the claim of Europe to this invention, but the weight of evidence is certainly in favour of its derivation from the East, where it was known and practised long antecedent to the earliest European attempts with which we are acquainted. It was adopted, however, in England at a very early period; and the Monkish historians made considerable use of it. Many specimens are to be found in the earliest editions of the Bible. Albert Durer, who flourished early in the sixteenth century, brought wood engraving to perfection.

Engraving on wood is a process exactly the reverse of copper-plate engraving. In the latter, the lines to be printed are

sunk, or cut, into the metal ; but in the former, all the wood is cut away except those parts on which are drawn the lines to be printed.

The wood used in this kind of engraving is, generally, box ; no other sort hitherto tried being found equal to it : for large coarse works pear-tree is used. American and Turkey box is the largest ; but all large wood of this kind is liable to split. For fine cuts the smallest logs are to be preferred, as it is almost invariably the best. If the wood is of a red colour, it is a sign of its softness, which renders it unfit for fine engraving. English box wood is superior to all others. Large red wood containing white spots, or streaks, will not answer the purpose of the engraver : a clear yellow colour, and as equal as possible over the whole surface, is generally the best criterion of box wood.

If kept too long in a dry place, it becomes unfit for the purposes of engraving. Box, if not well seasoned, is very liable to warp, or bend ; if not

required for immediate use, it ought to be placed on one of its edges, and not laid down flat. To prepare the wood for drawing upon, you must rub the surface with a little Bath brick, mixed with water ; as little as possible is to be used, as otherwise the block will absorb too much water, and be liable afterwards to split. When the thin coating is perfectly dry, it is to be removed by rubbing the block with the palm of the hand—no part of the powder ought to remain. The object of using the bath brick is to render the surface less slippery, and capable of affording a better hold to the point of the black lead pencil. Some artists wash over the surface with a mixture of flake white and gum-water : this practice is by no means a good one ; as, in the progress of engraving, a thin portion of the preparation will occasionally rise up before the engraver, and carry with it a part of the unengraved work, and leave the engraver to restore the part according to his ability and recollection. It is best to change the original colour of the wood

as little as possible. A piece of clear box is sufficiently light to allow of the most delicate lines being distinctly drawn upon it. The principal parts of the drawing are first washed in upon the block with Indian-ink, and when dry, rub the surface gently with a little dry finely-powdered Bath brick, before the drawing is completed with the black lead pencil.

Wood may be purchased at Mr. Martin's, 43, Middleton Street, Clerkenwell.

The drawing having been completed on the wood, it is necessary before beginning the engraving, in order to preserve it from injury, to cover it with paper—soft paper should not be used for this purpose, as it is liable to efface the drawing where the hand is pressed upon the block. Moderately stout post paper, with a glazed surface, is the best.

There are different ways of fastening the paper to the block. Some fix it with wafers, or gum, at the sides. The most convenient method of fastening the paper is to wrap a piece of stiff and stout thread

three or four times around the edges of the block. The paper cover can then be taken off at pleasure, to view the progress of the work. Some persons are in the habit of using magnifying glasses while at work; they are very injurious to the eyes, and are not required, except by elderly persons, whose vision is not strong.

Tools.—There are four kinds of cutting tools required for wood engraving, viz., gravers, tint tools, gouges, or scrapers, and flat tools, or chisels—of each of these there are various sizes.

Fig. 1.

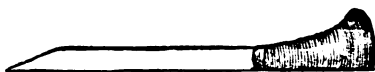

A straight Graver.

The cut, fig. 1, shows the form of a graver that is principally used for outlining, or separating one figure from another; though it is necessary that the

point should be very fine, yet the blade ought not to be too thin. About eight or nine gravers of different sizes, beginning from the outline tool, are generally sufficient: it is necessary to give the points their peculiar form by rubbing them on a Turkey stone.

Fig. 2.

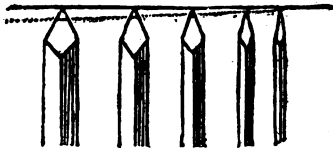

Gravers.

In the cut, fig. 2, are shown the faces, and part of the backs of five gravers of different sizes: the lower dotted line shows the extent to which the points of such tools are sometimes ground down by the engraver, in order to render them broader. These tools are used for nearly all kinds of work, except for series of parallel lines, called "tints."

Tint Tools are used to cut parallel

lines forming an even and uniform tint; they are thinner at the back, but deeper in the sides than gravers: about seven or eight of the different degrees of fineness are generally sufficient.

Fig. 3.



Gravers. Tint Tools. Gouges. Chisels.

The cut, fig. 3, will give an idea of the shape of the blades towards the point.

Gouges (see cut fig. 3.) are used for scooping out the wood in those parts that are to be left white towards the centre of the block; while flat tools, or chisels of various sizes, are chiefly employed in cutting away the wood towards the edges.

A grindstone, Turkey stone, and hone, are useful in grinding and sharpening these various tools. The latter is not much

used, but a graver that has received a final polish on a hone cuts a clearer line than one which has only been sharpened on a Turkey stone.

A sand bag is necessary to lay the block upon when at work.

Tools used in wood engraving are sold at Fenn's, Newgate Street.

To hold the graver in a proper manner you must employ the thumb at once, as a stay, or rest, for the blade, and as a check upon the force exerted by the palm of the hand; the motion being chiefly directed by the fore-finger. The thumb, with the end resting against the edge of the block is only applicable when the cuts are so small as to allow of the graver, when thus guided, to reach every part of the subject. When the cut is too large to admit of this, the thumb then rests upon the surface of the block. In order to acquire steadiness of hand it is best for the pupil to begin with the cutting of tints, or parallel lines, and the first attempts ought to be made on a small block. When the pupil can cut

these with tolerable precision, he should proceed to blocks of a larger size. He ought also to cut waved tints.

It is of great importance that the pupil should be able to cut tints well before he proceeds to any other kind of work. When uniform tints, both of straight and curved lines, can be cut with facility, the pupil should proceed to cut tints in which the lines are of unequal distances apart: to effect this, tools of different sizes are necessary; though in tints of a graduated tone of colour, the difference is sometimes entirely produced by increasing the pressure of the graver.

The cut, fig. 4, is a specimen of a tint cut entirely with the same graver; the difference being produced by increasing the pressure in the lighter parts.

Fig. 4.



Engraving in Outline.—The word outline in wood engraving has two meanings ; it is used, first, to denote the distinct boundaries of all kinds of objects ; and, secondly, the delicate white line that is cut round any figure or object, in order to form a boundary to the lines by which such figure or object is surrounded, and thus to allow of their easier liberation ; this last is called the white outline. As the white outline ought never to be distinctly visible in an impression, care ought to be taken not to cut it too deep or too wide.

The proper intention of the white outline is not so much to define the form of the figure, or object, but as a boundary to *other lines* coming against it ; the small shaving forced out by the graver becomes immediately released, without the point of the tool coming in contact with the true outline. After having cut the white outline of the subject (see fig. 5.), the next step is to cut a similar white line on each side of the pencilled lines which are to remain, and form the impression when it is printed (see fig. 6.)

In proceeding to engrave figures it is advisable to commence with such as consist of little more than outline, and have no shades expressed by cross lines.

Fig. 6.



Fig. 5.



In drawing, it must at all times be remembered that the printing will be the reverse of the drawing; the right side of the one will be the left side of the other. A proof cannot be taken until the principal parts of the subject are engraved, because of obliterating the design: when a proof is wanted it may be done very easily by means of a little ball-shaped dabber, made of leather, with wool inside, spread evenly upon this a little printer's

ink, dab it carefully on the block, so as to blacken it, but not to fill up the lines with ink ; then place a piece of damped paper upon the engraving, and rub the back with anything hard, which will transfer the ink on to the paper, and give a proof of the work.

Lithographic Drawing.

ALOYS SENNEFELDER, an actor of one of the theatres in Munich, was the inventor of lithography, about the year 1800. The art of lithography may be divided into two parts—the drawing and printing. The former requires but little practice, as any person who understands drawing may meet with success ; the latter is filled with difficulties. The first part consists in drawing on a stone, which has been previously made perfectly level and smooth, with an ink, or chalk, composed of greasy materials, in the same way as one would execute a drawing on paper with ink, or common chalk. The second

consists in taking the stone and obtaining impressions from it, as from a copper-plate. To obtain these impressions, the lithographic printer wets the whole surface of the stone, but as the greasy chalk, which constitutes the drawing, has a natural aversion for water, those parts of the stone alone which are not covered with the chalk, imbibe it. The printer, while the stone is wet, passes a thick and greasy ink over its whole surface, and the greasy lines of the drawing receive the ink, while the wet surface of the stone refuses to take it: a sheet of paper is now strongly pressed upon the stone, which, receiving the ink that has been applied to the drawing, gives a reversed fac simile of the original. The stone is wetted afresh, and again charged with ink; and thus a series of impressions are obtained.

MATERIALS, ETC.

Lithographic Chalk.—Chalk, to be of a good quality, must be firm, without being dry; and must attach itself to the

stone without clogging. When it is cut it should form itself into spirals, like wood shavings, and the texture should be close, like wax.

Lithographic Stones.—In order to withstand the necessary pressure, a stone a foot square must not be less than two inches in thickness. When stones are a great deal thicker than is necessary, they may be divided by a saw and sand; and after they have been squared, they must be rubbed face to face with sand and water, and the edges rounded with a file, and smoothed with a pumice-stone, using the sand finer and finer, by degrees, until the surface is perfectly smooth and even: different grains are given, according to the nature of the drawings: fine and delicate drawings require a very fine grain, while bold and spirited ones require a coarser one.

Preparation of Stones for Ink Drawings.—The stones having been prepared with fine sand, as is done for chalk drawings, must be well washed and carried to a table perfectly free from sand, or dust;

they must then be rubbed face to face with powdered pumice-stone and water; when perfectly smooth they must be again washed. This being done take a large pumice-stone, of a fine texture, and rub each stone separately with it, and with a circular motion; this must be done until the stone is polished, and perfectly free from grain, or scratches. A steel pen with a screw is an indispensable instrument for drawing lines: as the points soon get blunt by use, the moment that is the case, they must be ground with great care on a hone with oil. Quills and pens are very soon blunted by the nature of the stone, and of the ink. A miniature hair pencil is also an indispensable article: two thirds of the hairs must be cut off with a sharp pen-knife, so that only twelve or fourteen hairs remain.

Drawing.—The draughtsman must be careful that no greasy substances be allowed to come in contact with the stone, as these would mark in the printing. He must on no account touch the surface with his fingers, nor breathe upon

it; and it is necessary to lay a sheet of paper under the hand, to avoid any accident. The sketch may be made with lead pencil, or red chalk, observing that the impression will be the reverse of the drawing. If you wish to have a sketch on the side according to which it is drawn, the paper must be rubbed behind with red chalk, and applied to the stone, by passing a blunt needle over all the lines of the drawing, the red chalk which is on the other side, will repeat them all on the stone. It is necessary to have several port crayons ready, with chalk in them, as from the nature of the chalk it is apt to get softened by the heat of the hands. There are various modes of cutting the chalk: a wedge shape is best; and there are also various ways of holding it: it may be brought from right to left, held vertically inclined to the left, so that the point may follow last, or inclined to the right, so that its point may come first. Of all the different positions of the pencil this last is the one which causes the chalk to adhere the

more strongly to the stone. The chalk will also hold much better if the drawing be executed without going twice over the different parts, particularly with the soft tints. When the point of the pencil is turned up by drawing, that part must be taken off with the fingers, as the firm part alone must touch the stone. Different methods may be employed to correct a drawing; if it is wished to make a dark line fainter, parts of it may be picked out with the point of the scraper; if a line is to be completely scratched out, the sharp point must be employed; but this must only be done in case it is not intended to draw on that part again, as this operation destroys the grain of the stone; if a considerable portion of the drawing is to be rubbed out, the glass muller and fine sand must be made use of.

Drawing with Ink.—Ink drawings may be executed with the hair pencil, or steel pen, according to the style it is intended to imitate. The hair pencil is used for all line drawings, writing, ornaments,

maps, and landscapes ; of all the instruments employed for these purposes this is the most useful : with the brush you may imitate the finest engraving, and the most delicate lines. The steel pen is far from being equally good, but is more expeditious ; the mathematical steel pen is used for all straight lines and plans. Stones for ink drawings may always be employed as they come from the workman's hands : as the lines of an ink drawing should be as neat as possible, it is necessary that the stone should have the highest polish. Soft lithographic stones are not good for ink drawings, and in general the hardest stones are the best. Lithographic ink is employed in the same way as Indian ink ; it must be dissolved by rubbing it in a saucer with a few drops of rain water ; hard, or spring water, must never be employed. It is not possible to produce various tints with lithographic ink. The ink flows more readily from a hair pencil ; and if the lines are compared with those drawn with a pen, it will be found that the former are

more sharp and clear. It must be remembered that whether the ink is laid on thick or thin the lines print equally dark. The steel scraper must be used very sparingly in chalk drawings, as the grain is always destroyed when this tool is employed. It is however very different with ink drawings, for, in this case, the scraper does not spoil the surface.

Chalk, stones, &c. may be purchased at Straker's, Bishopsgate Street Within.

Engraving.

THE principal implements used in engraving with the tool are gravers, scrapers, a burnisher, points, or needles, compasses, an oil-stone, and a cushion, or sand-bag, for bearing the plate. Gravers are of two sorts, the square and the lozenge; several of each kind should be provided.

The square graver is used for cutting broad and deep strokes; and the lozenge for the fine, and more delicate ones. The scraper is used for clearing away the bur which arises in engraving. The bur-nisher is of service to polish the plate, and to take out any false scratches or strokes. The point, or, as it is generally called, the dry point, is a tool like an etching point, and which, being drawn hard on the copper, cuts a fine stroke, and raises a bur; when this is scraped off, there remains a more soft and delicate stroke than could be effected by any other means. The cushion is a bag of leather filled with sand; they are round, and about nine inches over, and three thick. The copper-plate being laid upon the cushion, the graver is to be held in the hand in such a manner that the handle of the graver may rest in the hollow of the hand, and the fore-finger extended upon the back of the graver towards the point. In forming straight lines hold the plate steady on the cushion, and where they are to be finer, press more lightly; and

use greater force where they are to be broader and deeper. In making circular and other curved lines, the hand and graver are to be held steadily, and the plate turned upon the cushion against the graver; though in some cases the plate and graver must be both moved at the same time, one against the other.

After part of the work is engraved it is necessary to scrape it with the scraper, passing it in the most level manner over the plate, to take off the roughness formed by the cutting of the graver. When you examine the part which is done, rub it with the oil rubber, made of a roll of felt, dipped in oil, which by filling the strokes with black, will show them, when the plate is wiped, to the best advantage.

In using the graver it is necessary to carry it as level as possible with the surface of the plate, and endeavour, by frequent trials, to acquire the habit of making strokes, both straight and curved, by lightening or sinking the graver with the hand, according to the occasion.

Strong broad strokes are formed by making two, or more, parallel lines with the graver, and then breaking them into one.

When the work is finished, if any scratches appear, or any part of the engraving be falsely executed, they may be rubbed out with the burnisher, and the part cleared with the scraper, and polished with the roll of felt, if necessary. The plate is then to be rounded off at the edges and corners, by using, first, a rough file, and afterwards, a finer one, and then polishing the edges with a burnisher.

In the conduct of the graver and dry point consists all the art, for which there are no certain rules to be given, all depending upon the genius of the artist. Some general directions may not be improper. In working, the strokes of the graver should never be crossed too much in a lozenge manner; and if the first lines be crossed by others at right angles, the areas formed by their intersections will be so many squares, which always

possess a certain hardness of appearance.

In a well-executed engraving we observe the following modes, and not unfrequently, many others, purely the invention of the engraver:—1. Single lines. 2. Lines crossed by others in a lozenge shape, not too acute. 3. Lines crossed at right angles, where a kind of obscurity is wanted. 4. Two courses of lines crossing at a lozenge, and intersected with a third, in a lozenge course, but more soft and tender than either of the other two. 5. Lines crossing each other at right angles, intersected by a third course of lines at a lozenge, which soften the squares, and render the work more elegant. 6. Strong lines, of a firm colour, at a considerable distance from each other, with a fine line between them; this is called *interlining*. 7. Firm lines, like the former, but crossing each other, and also interlined. 8. Round dots; often made in the flesh, and where soft shades are required.

Some of these methods, or similar ones,

introduced according to the judgment of the engraver, produce that wonderful effect, richness, and character we so much admire in excellent prints.

COLOURS FOR PAINTING ON VELVET,
SATIN, SILK, &c.

Menstrum. — Dissolve three or four pieces of gum tragacanth in a tea cup full of hot water—strain, and add a little of this to the colours, when you lighten them for a first coat or ground-work, otherwise the colours will run.

Orange.—Pour one ounce of distilled vinegar on a small quantity of hay saffron. When the colour is extracted, pour it off clear—add gum-water when used. This colour does not keep brilliant more than ten days in its liquid state, therefore make only a little at a time.

Golden Yellow.—Turmeric root one ounce, gamboge one drachm, rectified

spirits of wine one and a half ounce—digest in a warm situation for three or four days, then strain it.

Leaf Yellow.—French berries bruised one ounce, water three ounces—boil over a slow fire until reduced to one ounce and a half. A few minutes before it is removed from the fire, add one drachm of finely powdered alum. When cold, strain and bottle it.

Scarlet.—Mix as much of the orange colour with the pink saucer as may be necessary to produce a rich scarlet.

Rose may be made to any shade by adding more or less lemon juice with the pink saucer,—a diluted solution of citric acid in water will answer the same purpose.

Crimson.—Lay a coat of pink saucer, very deep on your intended crimson flowers, and afterwards a coat of carmine.

Carmine Liquid.—Carmine ten grains—liquid ammonia ten drops—distilled water one ounce,—shake frequently, it is fit for use in 20 minutes.

Dark Purple.—Liquid archill half an

ounce—twenty drops saturated solution of pearlash, and five grains of powdered alum—shake the ingredients well together in a bottle.

Light Purple.—Decoction of logwood half an ounce—powdered alum five grains—mixed.

Lilac.—Same as purple, but made much lighter with gum water.

Brown.—Vary the tints by adding either black, carmine, orange, or leaf yellow. An infusion of Spanish liquorice, or tobacco, makes an excellent brown.

Drab.—Mix a small quantity of Indian ink, with leaf yellow.

Grey.—Indian ink and blue, diluted with gum water.

Black.—Indian ink.

Green.—Vary the tints of green by adding blue or leaf yellow, as required.

Sap Green.—Used in its raw state.

Verdigris Green.—French verdigris one ounce—distilled vinegar, four ounces—boil for a few minutes over a slow fire, then add one drachm of cream of tartar—when cold filter and bottle for use.

Blue.—Prussian blue powdered, one drachm—oxalic acid, one drachm—distilled water, eight ounces—it is incompatible with the other colours, but it forms a beautiful ink, or stainer, without any colour.

Recipes, &c.

To make Red Chalk Crayons.—The following is the manner in which it is performed:—A quantity of *hematite* is ground in a porphyry mortar, with filtered water, until it be extremely divided, so as to form an impalpable powder. This powder is again diffused in a quantity of water sufficient to allow finer parts of the mixture to be passed through a fine sieve, placed above a large vessel filled with water. The liquid holding the hematite in suspension is then agitated; and after this allowed to rest four-and-twenty hours. At the end of this time, there is

formed at the bottom of the vessel a deposit of hematite, in the form of a very fine powder: the water is cautiously decanted from it.

To form crayons of this impalpable powder, a uniting medium is necessary. This is afforded either by gum arabic or isinglass, of which the proportions vary, according to the use to which the crayon is destined; less of it being required for soft crayons, which, consequently, yield their colour more readily; and more for the hard ones, which preserve their points longer. The following are the proportions, reduced from experiments, to be employed in the five kinds of crayons which we shall describe:

1. For the soft red crayons, which leave broad traces, 18 grains of dry gum arabic, to 1 ounce of the prepared hematite powder.

2. For harder crayons, 21 grains of gum to 1 ounce of the hematite powder.

3. For still harder crayons, and which make small and delicate marks, 22 grains of gum to 1 ounce of hematite.

4. For the hardest of this kind, 27 grains of gum to 1 ounce of hematite.

5. For crayons which leave shining traces, 36 grains of isinglass to 1 ounce of the prepared hematite powder.

The gum, or isinglass, is to be dissolved separately in a sufficient quantity of water, and their solutions passed through a linen cloth; the hematite powder is then added. The liquid is brought near to a gentle fire, until the mass is somewhat thickened by the evaporation of the water, when it is to be removed from the fire. The mixture is then to be carefully ground on a porphyry slab, to render it as intimate as possible, and is ready to be formed into crayons. To effect this, the mass, when it has become of a proper consistence, is forced through a cylinder: the sticks thus formed are dried, and divided into crayons, of two inches long. They are then sharpened at their points; and the hard crust, which had formed upon them while drying, is removed.

To Clean Copper-Plates. — Copper-

plates are cleaned by laying them on the hob near the fire, and pouring on them some spirits of tar, and then rubbing them with a small soft brush.

Painting on Vellum.—The illuminated missals, or coats of arms, &c., on vellum may be best done by the above colours, rather than by water colours with gall in them, as is often practised—the colours being put on with a brush, as in ordinary painting, also if more brilliancy be required for gold and silver, those metals may be put on in leaf, a coat being first put on with gold size—gold is best shaded with a bright transparent brown—silver with green; they are also in a considerable degree the same colours as are used by Mr. Baxter, in his beautiful art of Oil Colour Printing.

Painting Transparencies.—The paper (or other material) must be fixed in a straining frame, in order to place it between the eye and the light, when required. After tracing the design, the colour must be laid on, in the usual method of stained drawings. When the

tints are got in, place the picture against the window on a pane of glass framed for the purpose, and begin to strengthen the shadows with Indian ink, or with colours, according as the effect requires; laying the colours sometimes on both sides of the paper, to give greater force and depth of colour. The last touches for giving final strength to shadows and forms, are to be done with ivory black or lamp black prepared with gum water, as there is no pigment so opaque and capable of giving strength and decision. When the drawing is finished, and every part has got its depth of colour and brilliancy, being perfectly dry, touch very carefully with spirits of turpentine, on both sides, those parts which are to be the brightest, such as the moon and fire; and those parts requiring less brightness, only on one side. Then lay on immediately, with a pencil, a varnish, made by dissolving one ounce of Canada balsam in an equal quantity of spirit of turpentine. Be cautious with the varnish, as it is apt to spread. When

varnish is dry, tinge the flame with red lead and gamboge, slightly touching the smoke next the flame. The moon must not be tinted with colour. Much depends upon the choice of a subject. The great point to be attained is a happy coincidence between the subject and the effect produced. The fine light should not be too near the moon, as its glare would tend to injure her pale silver light; those parts which are not interesting should be kept in an undistinguishable gloom; and where the principal light is, they should be marked with precision. Groups of figures should be well contrasted; those in shadow crossing those that are in light, by which means the opposition of light against shade is effected.

The Art of Painting in Water Colours.

COLOURING is the art of giving to every object in a picture its true and proper hue, as it appears under all the various circumstances or combinations of light, middle tint, and shadow.

Although a knowledge of the science of optics may be of great service to a painter, yet the pictures of the best colourists are universally allowed to be the books in which a young painter must chiefly look for the rules of colouring. As soon as the student has laid a proper foundation for good colouring, by studying the best masters, he should turn all his thoughts to truth and nature.

MATERIALS, ETC., REQUIRED.

Colours.—Colours are sold, with few exceptions, in single cakes, or in boxes, containing from twelve to forty-eight cakes: many of these are mixtures, or

M

duplicates, with slight variations, which tend to perplex the beginner till a knowledge of their several properties has been acquired by practice and experience.

Painters of eminence have been known to obtain all the variety of tints which they required from the primitive colours, yellow, red, and blue, such as a cake of yellow ochre, a cake of red ochre, and a cake of indigo. A very great variety of tints may be produced by skilfully intermingling these three colours. Correctly speaking black is not a colour, but the absence of all colour. White is the union of the three primitive colours in the proportion of three yellow, five red, and eight blue. In common language both black and white are called colours.

Of the three primary colours yellow partakes most of the nature of white, being the lightest of all decided colours. Its contrast colour is purple, a compound of the other two primaries. It constitutes, in combination with red, the secondary orange, and when compounded with blue it produces the secondary green.

Red, the second of the primaries, is the most positive of all colours, holding the middle station between yellow, which is most allied to light; and blue, which is most allied to shade. Its contrasting colour is green, a compound of yellow and blue.

Blue is the third of the primary colours, and nearest in relation to shade or coolness. Its contrasting colour is the secondary orange. In order to obtain a knowledge of the harmony of every colour applicable to the practice of painting, the student must assiduously investigate the numerous combinations observable in nature, and perseveringly endeavour to reproduce these artificially.

The following is a list of the principal colours:—Prussian blue, blue verditer, Antwerp blue, ultramarine, smalt, intense blue, cobalt, Indian red, lake, light red, Indian lake, scarlet lake, Italian pink, madder lake, vermilion, gall stone, gamboge, Indian yellow, yellow ochre, Roman ochre, burnt umber, raw umber, bistre, burnt terra sienna, raw terra sienna, pur-

ple brown, sepia, madder brown, Cologne earth, vandyke brown, brown ochre, brown pink, sap green, green verditer, neutral tint.

The student should be provided with the best hard drawing paper. For subjects in which minute and fine delineations is required, the paper should be smooth on the surface, but when the subject is of a rural character, in which all the shagginess of nature is to be introduced, the paper should be of a rough description. Drawing papers have frequently a greasiness of surface, which prevents a tint from being spread with evenness; the slightest infusion of gall into the water with which the tint is made will remedy the defect, or the surface of the paper may be sponged with the gall and water before fastening it on the drawing board.

A few camel hair pencils must be provided, two *flat inch tins* to distribute a tint over a large space, some *swan quills* to wash in smaller spaces, *hen quills* to pick in minute parts. The student should have a

few small delf saucers, in which to mix the tints, and two cups, or glasses, to contain water; one to be preserved pure, and the other in which the pencils are to be washed.

Having sketched in the principal objects of your picture, not too dark, place the drawing board in a slanting position, and have your saucers and glasses, containing pure water, on the right hand, near the pencils, with the window on the left, so that the sunshine does not fall on the drawing board. Before you begin have all your colours ready, with a piece of paper to try your colours on. Mix a tint for the sky of Prussian blue; a neutral tint for the clouds composed of Indian red, and Prussian blue; before mixing these wash over your drawing with clear water, and before it is quite dry lay in the dead colours, beginning with the blue tint, and wash over with the neutral tint the whole of your drawing, except the brightest lights; in that part there needs no great pains, but a masterly freedom is required; this, although apparently

coarse, will afterwards produce a good effect. The colours must at first be laid on thin, to be deepened or mellowed afterwards, as may be necessary : the quicker they are laid on the better. Mix the tint well with the pencil to be used, and always let that be rather larger than might seem to be required. The pencil is properly charged for use when it has been stirred into the tint, and gently touched or passed two or three times on the edge of the saucer ; this must be done carefully, because if the pencil contain too much tint there is a difficulty in spreading it neatly. If the pencil contain too small a quantity it will be impossible to spread the tint. The first wash, or dead colouring, being dry, you must finish the clouds ; for this purpose the grey, or neutral tint, must be used, made rather dark, by more of each colour. Begin with the light flying clouds, and end with the mass or body of shade, varying the grey more or less, as may be required. You may bring the colour down over where the distances are to come, and soften it off by mixing

water with your pencil as you proceed. In painting a *warm sky* the following colours will be required :—Prussian blue, yellow ochre, red lake, light red, Indian red. It will be found most convenient to turn the drawing upside down, then taking a flat brush, dipped into the yellow ochre, stain the paper about one-third downward, leaving a wet edge: this colour may be carried over the trees and distant objects with another flat brush, and with the light red, or Indian red, beginning immediately where the yellow ochre terminates, proceed another third downward, again leaving off with a wet edge: with a third flat brush apply the Prussian blue in a similar manner, to the termination or head of the picture.

The remote *distance* must be laid in with the Prussian blue and grey, like that of the shadows of the clouds, nearest the strongest lights, which grey may be warmer or colder, according to the subject. The tops of the most distant mountains must be painted so faintly as to seem to lose themselves in the air.

When broad tints have not been evenly distributed, or laid on too strongly, they may be corrected by a sponge, softened and nearly filled with water, passed gently, two or three times, over the whole of the subject, taking care to cleanse the sponge the instant it is observed to have the least tendency to soil any of the parts which should be cleaned. Sponging, it must carefully be remarked, should never be attempted after the compound tints have been introduced: previous to this it has a fine effect on the sky and the remote distance, making them appear as if the air were really interposed to produce the ærial perspective. Sponging should be used with great caution, for no pure tint can be laid on paper that has been sponged.

Middle Distance. — The parts of a picture between the foreground and the remote parts: it is here that the chief excellencies of a picture should be aggregated. A careful obscurity is often all that is sufficient for the distance; and a few bold touches may serve as a fore-

ground; but in the middle parts, harmony of colouring, accuracy of drawing, and tasteful grouping, are essentially necessary: it requires the same colour as the distance, made darker by the addition of blue and Indian red, or red lake; leaving untouched the spots for extreme lights.

The Foreground is that part of a picture nearest the eye: for colouring it requires a dark grey, made of Indian red, yellow ochre, and Prussian blue. The lights, of light red and yellow ochre, laid on separately, or combined, otherwise it may be of warm greens. It is here that the warmer tints and boldest touches are generally found, it being necessary that each object placed so near to the observer should be drawn with the utmost exactitude: each rock, each tree, with all its characters; each flower, in its proper colours and natural habit.

Trees must now receive their first colour, with a light green, or pale yellow, for the lights: the same greys for the shades as in the foreground: strengthen

slightly the shades to trees, buildings, and other objects in the distance. Then deepen the shades in the mid-distance, and mark more precisely the figures of the respective objects: treat the foreground in the same manner, and add to the shadows on the water. In pursuing this operation the various shades of the distance, and its several objects, may be rendered more distinct by a little additional strength, using the grey before-mentioned; those of the middle ground, and of the foreground, may be strengthened by the same greys: the same rule may be applied to the trees, &c. This is called the dead colouring. It will naturally be varied according to taste and peculiarity of subject. Much of the effect called *harmony* depends on its judicious management: tinge the distant trees with green, varied, where requisite, with the slightest tinge of red lake and ochre, or burnt terra sienna. The dead colouring being now finished, without exclusion of other colours, form greens, for the distance, of Prussian blue and

yellow ochre, very thin, so as not to overpower the greys. These may be warmed with the slightest tinge of lake.

To the middle ground you may now apply additional colour upon the lights and other parts. The requisite colours will be light red, yellow ochre, and Prussian blue, combined or separate, and, occasionally, a little red lake, or Indian red. The foreground is to be treated in a similar manner, but its stronger tints may consist of blue, yellow ochre, and Indian red; the greys continue to preserve distinctness: should red be required in the distance, for roofs of houses, &c. light red should be used. The greens in the middle and foregrounds may be now introduced, and varied according to the subject. We now approach to the finish by making the whole subject more harmonious by a broad distribution of light and shade, bringing forward all projections, deepening shadows, and forming the smaller objects in the foreground, &c. in the most perfect manner. A little fine bistre may be used in the foreground

should the colours made by the mixture of yellow ochre, Indian red, or Prussian blue, not be sufficiently warm, or strong. You now finish by taking out the lights. This process will be required when a wrong colour has been laid on a mass, or where it is necessary to introduce touches of light on a strong tint. Pure water is applied, by means of a pencil, to the parts where taking out may be required; and just before the water disappears, while the part remains moist, press it with a clean linen cloth, gently wiping it till the colour is removed: if it be required to clear the paper entirely of the colour it may be effected by means of Indian rubber; some artists, to give the sparkling lights to water, use a pen-knife, and a much better effect is produced by taking out than by any other means.

In making the lights and shades of a landscape it must never be forgotten, that whatever place the sun may be in, the light can fall but one way, and that all the difference possible in the shades are, their degrees of strength between morn-

ing, evening, and noon. Experienced artists always prefer morning and evening, as productive of those golden and purple tints which catch upon objects half buried in deep shadow, and give a beautiful effect to the landscape. Claude Lorrain was almost the only painter who thought himself equal to representing the sun: that he succeeded to admiration must be acknowledged; but it is extremely doubtful whether his pictures will ever be equalled. As one step towards imitating the brilliancy of the orb of day it has been the custom to suppose the sun just beyond the boundary of the picture, by making the sky clear and light on that side, and gradually fading thence through the landscape. As this method is founded upon just principles, the young artist may safely adopt it, though not as an indispensable rule, for the light breaking through clouds, and illuminating the centre, or front of a view, has an excellent effect, especially if that spot is animated by human figure, or cattle. Many conflicting opinions have prevailed with

respect to the propriety of introducing groups of human figures in landscape; it may be alleged, with some show of reason, that too many figures have a tendency to disturb the requisite repose of a beautiful scene, but, on the other hand, the want of figures most certainly tends to excite an idea of desertion, if not of desolation. A medium between these two extremes may, perhaps, be the most judicious and conformable to good taste. Groups of figures may often be seen in the pictures of Teniers, Wouvermans, Claude, and Cuyp; supported by such authorities we may well consider figures an excellent adjunct for imparting richness and colour to foregrounds.

Taste is not subject to fixed rules; but natural landscapes are luminous, although artists of celebrity have reduced the light to one eighth of the size of their subject; and a dark picture requires an excellent situation in which to be viewed, or much of its beauty will be lost. Rembrandt is the only master who obtained celebrity in landscape by painting artificially, and

otherwise than nature dictated. Claude, Poussin, Vernet and Gainsborough painted in the fields, and their representations are expansive breadths of light, and strikingly beautiful.

Flower Painting.

To acquire proficiency in the painting of flowers nature must be constantly and carefully studied, endeavouring to discover among the colours on the palette such original, or compound, tints as will come the nearest to the real object. Much useful information may also be obtained by studying and imitating the best drawings, or paintings of flowers; to learn by what practices and arrangement of colours the various tints of the original may be best imitated. In general flowers are drawn and laid in the same

way with all other figures, but the manner of completing and finishing them is different; for they are first formed by large strokes and traces, made and turned in the way the smaller strokes are to be placed in the finishing; which is done by very fine small strokes, without cross-hatching, or dotting, unless, as is the case in some kind of flowers, the surface of the natural object be spotted. These very fine small lines must be repeatedly gone over with the pencil, until all the parts, both dark and light, have received their whole force. As an example of flower painting it will be sufficient to show how roses are done:—When the contour and several leaves are sketched, if it be for a red rose, trace these outlines with carmine, touched with a very pale lay of carmine; then the shadows are to be drawn with the same colour, a little darker, strengthening it more and more by repeated touches, according to the darkness of the shades. This is performed by large strokes of the pencil, at first, and finished by finer strokes of the same

colour; all lying precisely in the same direction and inclination of the leaves with the rose you copy, or with the strokes of the engraving, if you copy a print; taking care to blend the light and dark parts; heightening the brightest parts of the leaves. The hearts of the roses are made darker than the rest, and a little indigo must be mixed with the other colours for shading the first leaves, when the flowers are full blown, to give them an air of being somewhat decayed: the best dead colouring for the seed is gamboge, mixed with a little sap green, for the shadows.

Variegated roses, or those streaked with different colours, ought to have the ground paler than others of one colour, that the streaks, or variegations, may be the more apparent. These are laid on with carmine, darker or lighter, according to the point of light falling on, or reflected from, the leaves of the flowers. The stalks, leaves, and buds of roses, of all kinds, are formed with verditer, in which is mixed a small proportion of gamboge

and masticot ; and for the shades, sap green is added, diminishing the other colours as the shades grow deeper. The leaves have more of a blue tinge on the outside than on the inside, and, therefore, must be dead coloured with sea green, or sap green, mixed with the shade green, and the fibres on the outside must be made brighter than the ground, but those on the inside darker : the prickles upon the buds of roses are painted with gentle touches of carmine, laid in different directions ; and those on the stalks are formed with verditer and carmine, and shaded with carmine and bistre ; the lower parts of the stalks being made redder than the top.

Oriental Tinting, or Poonah Painting.

ORIENTAL tinting is very easily acquired by persons who have no knowledge of drawing, and by following the directions contained in the following pages, there is very little doubt of succeeding in it.

The colours for the above painting are as follows:—*Blues.* Smalt, cobalt, Prussian blue. *Yellows.* Chrome yellow, No. 1, chrome yellow, No. 2. *Greens.* Prussian green, Hooker's green, No. 2, verdigris. Bright scarlet, carmine, crimson lake, burnt umber, burnt terra sienna, lamp black.

The best colours, in cakes, are sold by Ackerman, Strand, and Newman, Soho Sq.

The Bristol, or card board and paper best for oriental tinting is from two to three sheets in thickness. Ivory board, or any that has a fine smooth texture, will do.

DIRECTIONS FOR HOLDING THE BRUSH.

You will require about a dozen poonah brushes of different sizes.

The brush is not to be held in the same way as for the ordinary method of painting (after the manner of a pen or pencil) but quite upright, working immediately upon the end of the brush, not forgetting to keep the right arm elbow perfectly free from resting upon

the table, giving, at the same time, a circular or rotory motion to the brush. At all times be particular to keep the brush upright, and not allow it to incline either on one side or the other, for in so doing you will work with the edge of the brush, and produce a roughness in your work, and spoil the good effect. If you use the ivory board lay on your colours as dry as possible; the ivory board being smooth the less moisture that is used the better. If you use any board, or paper, that is not so smooth as the above and the colours as dry, as for the ivory board, you will find it produce a mottled appearance. Should the painting appear to be much mottled, by adding a little moisture to your brush, or colour, you will, by a little practice, produce the desired effect. Be careful also not to use too much moisture, for in so doing you will destroy the mottled appearance, and should that be the case the work will be rough and hard. When you have finished the painting part, take a *clean* dry brush, and rub over the leaves, and you will find it will give them a gloss,

and produce a lively effect. Should you wish to produce a yellow green leaf, first lay on a coat of chrome yellow, No. 1, and over that Prussian green.

**TO FORM YOUR THEORUMS OR
FORMULAS.**

To copy a group of flowers proceed as follows: take a piece of tracing paper the size of your group, and secure it at each corner with a small weight, or pin; then, with a fine black lead pencil, trace every part of it, dividing each in two parts, by a stroke over the centre, along the vein: having finished your tracing, take a sheet of drawing paper, not too stout, fold it to the size of your group, and cut it in five or six pieces—that being a sufficient number for a large group; then take one of the pieces and pin it to the tracing paper copy at the edges. Then proceed to pierce the traced copy through; and through the under paper also, with a strong needle, put into a cork, or a small handle, and let your piercing be very close, or you will fail: it must be done upon a

piece of hard board, one inch thick, and covered with a piece of woollen cloth; and after the piercing is done, you must have a small hole at each corner, as guides, the size of a pin head.

Having proceeded thus far, take some Prussian blue, powdered very fine; then take the pierced paper, and lay it upon one of the pieces you intend for your theorem, and holding it fast with your left hand, with a knife strew a little of the Prussian blue upon it; then with a scrub, made of a No. 4 painter's sash tool, by cutting off one half the length of the bristles, by tying a piece of string round it, and cutting them off with a sharp knife; with this rub the blue through the piercing, not forgetting the guides also: when you remove the pierced paper you will have a complete sketch of your group: repeat the same process upon each of your papers you want for the theorem, and proceed as follows;—Lay the paper with the sketch upon your cutting-board (the back of the piercing-board will do), and cut out any part of it with a sharp-

pointed pen-knife; then cut out any other part that does not interfere with the part you have already cut out, and so on until you have cut out as much as you may think will do, without reducing your theorem too much: that being done, mark it, No. 1; then take the paper you intend for No. 2, and lay it upon your cutting-board; this done, take No. 1, and lay it on No. 2, and, with a black pencil, make a small cross, or mark, through every opening of No. 1; after this is done proceed to any of the parts of No. 2 that are not crossed, until you think you have cut out sufficient, and mark it, No. 2, and repeat the same process with every one you have cut; you will soon perceive when your theorem is complete.

TO MAKE VARNISH FOR THE THEORUMS.

To one ounce of shell-lac bruised, add three ounces of spirits of wine, put them together in a half-pint bottle; place it near the fire, within the corner of the fender for one day, shake it occasionally, and it will be ready for use; give your

theorem two coats of it with a brush, and they will be ready for use in a few hours.

TO TAKE A SKETCH FROM NATURE.

Have a frame, made one inch and a half in depth, and about one foot square, with a groove in it, to receive a glass, in the same way as a window is secured with putty; then, by laying your subject under the frame and glass, and laying your tracing paper upon the glass, you will be able to produce a sketch from the subject under the frame; after which piece and cut a theorem, and paint it according to the natural subject.

To shade your leaves, or flowers, clean your theorem, and then place it on the leaf you wish to shade, as if you were going to paint it again; this done, slip it off your theorem leaf to the right, or left, as required, and shade it with your brush, and the following colour lightly—lamp black, with a little Prussian blue, and a small touch of chrome yellow, No. 1.

The Art of Staining Glass.

There are three modes of coloring glass, one by laying upon it a coat of some transparent colored varnish, or drawing a design in various colors, as is exemplified in painting magic lanthorn sliders. 2nd. By mixing with it during its first manufacture and while in a state of fusion, some of the metallic oxides; in this manner coloured drinking glasses, hyacinth glasses, beads, illumination lamps, and often sheet glass is made. Also, upon this process, if well conducted, depends the successful imitation of fictitious gems, or as they are commonly called *paste* jewels. The following materials are usually employed at the glass houses to produce the various tints required in the articles that are ordinarily made of coloured glass.

Blue glass is formed by means of oxyde of cobalt. *Green* by the oxyde of iron, or of copper. *Violet* by the oxyde of manganese. *Red* by a mixture of oxyde of iron and of copper. *Purple* by the

purple oxyde of gold. *White* by the oxydes of arsenic and of zinc. *Yellow* by the oxyde of silver.

In staining glass, the colored ingredients are mixed with water, or some other fluid vehicle, by means of which they are spread over the surface of a plate of glass, and when dry, are exposed to such a degree of heat, as by experience has been found to be sufficient. The color is then rubbed off from the surface of the glass, to which it does not adhere; and those parts of the plate which have been thus covered are found to have acquired a permanent and transparent tinge or stain, doubtless from some particles of the color having been absorbed, and fixed in the pores of the glass.

In all the compositions for staining glass, silver, in some form or other, enters as an essential ingredient.

Preparations of Silver.—Take 2 or 3 ounces of pure nitric acid; dilute it with three times its bulk of distilled water; put it into a Florence flask, or any other convenient glass vessel, and add to it refined silver by small pieces at a time, till the acid,

though kept at a warm temperature, refuses to dissolve any more. After standing quiet for some hours, pour off the clear liquor in a clear ground stoppered phial, and label it *Nitrate of Silver*.

No. 1.—Dissolve common salt in water, and add nitrate of silver drop by drop, till it ceases to occasion any precipitate; there will thus be obtained a heavy white curd-like substance, which must be well washed in hot water, and dried; by exposure to light, it becomes of a dull purple color. It is known by the name of muriate of silver, or *luna cornea*.

No. 2.—Dissolve subcarbonate of soda in water, and add nitrate of silver, as before described. The white precipitate thus obtained, when washed and dried, is ready for use. It is called the carbonate of silver.

No. 3.—Dissolve subcarbonate of potash in water, and proceed precisely as directed for No. 2. The white powder thus obtained is also carbonate of silver.

No. 4.—Dissolve phosphate of soda in water, and proceed as already mentioned.

The precipitate thus obtained is of a yellowish colour, and it is called phosphate of silver.

No. 5. — Take any quantity of pure silver rolled out into thin plates, and put it into a crucible, together with some sulphur. When the crucible has been a short time on the fire, the sulphur will first melt, and then will gradually burn away with a blue flame. When the flame has ceased, add some more sulphur, and proceed as before; then take the silver out, and heat it red in a muffle; it will now be white, and very brittle; and after having been reduced to powder in a mortar, is fit for use.

No. 6.—Take any quantity of a dilute solution of nitrate of silver, and put into it a stick of metallic tin; warm it a little, and the silver will be precipitated in the form of metallic leaves on the surface of the tin. Scrape it off, wash it in warm water, dry it, and grind it in a mortar.

No. 7.—Take any quantity of nitrate of silver, and put into it a piece of copper plate; then proceed precisely as in No. 6.

The foregoing preparations of silver mixed with other ingredients, in the proportions about to be described, compose all the varieties of pigment which are requisite for staining glass.

YELLOW.

	PARTS BY WEIGHT.
Take silver No. 2	1
Yellow lake	1

Mix the ingredients and grind them well, with oil of turpentine :—lay it on thin.

Take silver, No. 1	1
White clay precipitated from a solution of alum by subcarbonate of soda	3
Oxalate of iron, prepared by precipitating a clear solution of sulphate of iron by oxalate of potash	3
Oxide of zinc	2

Let the silver be ground first in water with the oxide of zinc, and then with the other ingredients.

This is intended for floating on thick.

Take silver No. 3	1
Yellow lake	1

Grind them in spirits of turpentine and oil, and lay the mixture on very thin.

Take silver No. 4	1
Yellow lake	1
White clay	$\frac{1}{2}$

Grind them in spirits of turpentine and oil, and lay the mixture on thin.

ORANGE.

Take silver No. 6	1
Venetian red and yellow ochre, equal parts, washed in water, and calcined red.	2

Grind the ingredients in spirits of turpentine, with thick turpentine, and lay the mixture on thin.

Take silver No. 7 1
 Venetian red and yellow ochre 1

Grind in turpentine and oil, &c. as the foregoing.
 If the entire panes of glass are to be tinged orange, the proportion of ochre may be greatly increased. The depth of the tinge depends in some measure on the heat of the furnace, and on the time that the glass is exposed to it, which though easily learned by experience, cannot be made the subject of precise rules.

RED.

Take silver No. 5 1
 Brown oxyde of iron, prepared in heating scales of iron, then quenching them in water, reducing them to a fine powder, and lastly, calcining it in a muffle 1

Grind the ingredients with turpentine and oil, and lay the mixture on thick.

Take of antimonial silver, prepared by melting together one part of silver and two parts of crude antimony, and pulverizing the mass 1
 Colcothar 1

Grind the ingredients in turpentine and oil, and lay the mixture on thick.

Take of antimonial silver, prepared as above 1
 Venetian red and yellow ochre, of each 1
 Grind, &c. as before

When the whole panes of glass are to be tinged, the proportions of ochre and colcothar may be increased, and the ingredients should be ground in water.

On laying on the colour.—The method practised by many stainers of glass is to draw an outline in Indian ink, or in a

brown colour, ground with turpentine and oil, and then to float on the colour thick, having previously ground it with water. But in this way of proceeding, it is very subject either to flow over, or to come short of the outline, and thus render the skill of the draughtsman of little effect.

Another method is to draw the pattern in Indian ink, and having ground the colour as fine as possible in spirits of turpentine, to add oil of lavender, and to cover the outline entirely with this composition.

When it has become dry, work out the colour with the point of a stick and a knife from those parts that are not intended to be stained; the most delicate ornaments and most intricate designs may thus be executed with exactness and precision.

If the colour is required to be laid on so thick that the outline would not be visible through it, let the colour be first laid on as smoothly as possible, and when it has become dry, draw the outline upon

it, with vermilion water-colour, and work out the design as before.

The artist should contrive to charge his furnace with pieces, the colour of which is ground in the same vehicle, and not to mix in the same burning, some colours ground in turpentine and some ground in water. The pieces must also be very carefully dried, and must be placed in the furnace when this latter is moderately warm.

FINIS.



T. SLOPER, PRINTER, HIGH STREET, MARY-LE-BONE.

1
2
3
4
5
6
7
8
9
10
11
12
13
14
15
16
17
18
19
20
21
22
23
24
25
26
27
28
29
30
31
32
33
34
35
36
37
38
39
40
41
42
43
44
45
46
47
48
49
50
51
52
53
54
55
56
57
58
59
60
61
62
63
64
65
66
67
68
69
70
71
72
73
74
75
76
77
78
79
80
81
82
83
84
85
86
87
88
89
90
91
92
93
94
95
96
97
98
99
100

